

LOUDEN RESIDENCE PERMIT SET



CONCEPTUAL PROJECT IMAGE



VICINITY MAP

LEGAL DESCRIPTION:

LAKEMONT ADD UNREC PARCEL A MERCER ISLAND SHORT NO 79-06-17 REC NO 7909100629 SD PLAT DAF - ALL TR 3 & SH LDS ADJ

CONTACT INFORMATION:

ARCHITECT:
REGAN McCLELLAN, AIA
McCLELLAN ARCHITECTS
3309 WALLINGFORD AVE N
SEATTLE, WA 98103
(206) 728-0480
REGAN@MCCARCH.COM

STRUCTURAL ENGINEER:
GARY GILL S.E.
gill26608@yahoo.com
(206) 992-2728

CONTRACTOR:
JIM CORNELL
SCHULTZ MILLER
425-287-1950
jcornell@schultzmiller.com

GEOTECHNICAL ENGINEER:
MARC McGINNIS
GEOTECH CONSULTANTS, INC.
(425) 260-1116 (Mobile)
marcm@geotechnw.com

ENERGY/MECHANICAL CODE COMPLIANCE:

- 1) WORK TO COMPLY WITH THE 2015 WSEC AND 2015 IMC.
- 2) ALL NEW BUILDING ELEMENTS WILL FOLLOW THE PRESCRIPTIVE REQUIREMENTS:

VERTICAL GLAZING (U):	0.30
OVERHEAD GLAZING (U):	0.50
DOOR (U):	0.30
CEILING:	R38 ADV. or R-49
VAULTED CEILING:	R-38
WALL ABOVE GRADE:	R-21 INT
WALL INT. BELOW GRADE:	R-21 TB
WALL EXT. BELOW GRADE:	R-10
FLOOR:	R-30
SLAB ON GRADE:	R-10
- 3) A MINIMUM OF 75 PERCENT OF ALL LIGHT FIXTURES SHALL BE HIGH EFFICACY PER WAC 51-111R.
- 4) PERMANENTLY MOUNTED EXTERIOR LIGHTS FIXTURES WILL BE HIGH EFFICACY UNLESS EQUIPPED WITH BUILT-IN PHOTO CONTROL SENSOR PER WSEC 505.2.

- 5) ALL BATHROOMS AND TOILET ROOMS TO BE EQUIPPED WITH A MINIMUM 50 CFM INTERMITTENTLY OPERATING SOURCE SPECIFIC EXHAUST FAN. ALL KITCHENS TO BE EQUIPPED WITH A MINIMUM 100 CFM INTERMITTENTLY OPERATING SOURCE SPECIFIC EXHAUST FAN PER IRC M 1507.4.

PROJECT DATA:

PARCEL NUMBER: 413930-0015
PROJECT ADDRESS: 3315 97TH AVE SE
LOT SIZE: 22,355 SF
ZONE: R8.4
OCCUPANCY TYPE: R-3
CONSTRUCTION TYPE: V-B
AUTOMATIC SPRINKLER SYSTEM: EXIST
PROJECT DESCRIPTION:
REMODEL EXISTING INTERIOR OF HOME,
REPLACE EXISTING PATIO ROOF, RENOVATE
EXTERIOR FINISHES

SHEET LIST:

- GENERAL:**
G0.0 TITLE SHEET
G0.1 GENERAL CONDITIONS + ABBREVIATIONS
- SURVEY**
- ARCHITECTURAL:**
A0.1 SITE PLAN AREA CALCULATIONS
A0.2 FLOOR AREA CALCULATIONS
A2.0 FIRST FLOOR PLAN - SOUTH
A2.1 FIRST FLOOR PLAN - NORTH
A2.2 SECOND FLOOR PLAN - PARTIAL
A3.0 BUILDING ELEVATIONS
A3.1 BUILDING ELEVATIONS / OPENING SCHED
A4.0 WALL SECTIONS
A4.1 BUILDING SECTIONS / DETAILS
- STRUCTURAL:**
S1.0 GENERAL NOTES & ABBREVIATIONS
S2.1 BASEMENT FOUNDATION PLAN
S2.2 MAIN FLOOR FRAMING PLAN
S2.3 2ND FLOOR FRAMING PLAN
S2.4 EXISTING ROOF FRAMING PLAN
S3.1 FOUNDATION DETAILS
S4.1 TYP FRAMING DETAILS
S4.2 FRAMING DETAILS

PROJECT:
LOUDEN RESIDENCE
3315 97TH AVE SE
MERCER ISLAND, WA

ISSUE:
PERMIT SET 2020-04-13

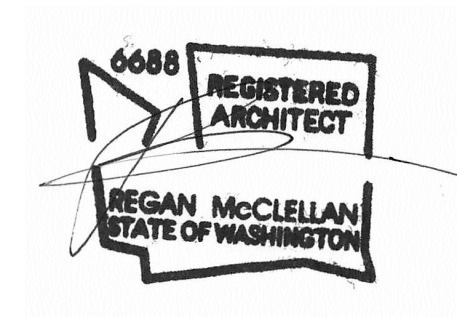

DATE:
MARCH 13, 2020

SHEET TITLE:
TITLE SHEET

SHEET:

G0.0

LOUDEN RESIDENCE PERMIT SET

ABBREVIATIONS:

ABV	ABOVE	IBC	INTERNATIONAL BUILDING CODE
ACQST	ACOUSTIC, ACOUSTICAL	INSUL	INSULATION
ACCY	ACCESSORY	INT	INTERIOR
ADDM	ADDENDUM	JB	JUNCTION BOX
ADDL	ADDITIONAL	JNT	JOINT
ADJ	ADJUSTABLE	LAV	LAVATORY
AFF	ABOVE FINISHED FLOOR	LTG	LIGHTING
AFG	ABOVE FINISHED GRADE	MATL	MATERIAL
ALT	ALTERNATE, ALTERNATIVE	MAX	MAXIMUM
ALUM	ALUMINUM	MDO	MEDIUM DENSITY OVERLAY
ANCH	ANCHOR	MDF	MEDIUM DENSITY FIBER BOARD
APPROX	APPROXIMATELY	MECH	MECHANICAL
ARCH	ARCHITECT, ARCHITECTURAL	MFR	MANUFACTURER
BB	BASEBOARD	MIN	MINIMUM
BLDG	BUILDING	MO	MASONRY OPENING
BLKG	BLOCKING	MTL	METAL
BLW	BELOW	N	NORTH
BM	BEAM	(N)	NEW
B/O	BOTTOM OF	NIC	NOT IN CONTRACT
BRD	BOARD	NTS	NOT TO SCALE
BTW	BETWEEN	OCCUP	OCCUPANTS, OCCUPANCY
CAB	CABINET	OL	OCCUPANCY LOAD
CALC	CALCULATION	O/	OVER
CL	CENTERLINE	OC	ON CENTER
CJNT	CONTROL JOINT	OPG	OPENING
CLG	CEILING	OPP	OPPOSITE
CLR	CLEAR	ORD	OVERFLOW ROOF DRAIN
CMU	CONCRETE MASONRY UNIT	PNT	PAINT
CNTR	COUNTER, COUNTER SUNK	PEN	PENETRATION
COL	COLUMN	PERP	PERPENDICULAR
CONC	CONCRETE	PJ	PANEL JOINT
CONT	CONTINUOUS	PL	PROPERTY LINE
CORR	CORRIDOR	PLAM	PLASTIC LAMINATE
CPT	CARPET	PLWD	PLYWOOD
CT	CERAMIC TILE	PR	PAIR
CTR	CENTER	PRELIM	PRELIMINARY
DBL	DOUBLE	PT	PRESSURE TREATED
DEG	DEGREE	PTN	PARTITION
DEPT	DEPARTMENT	R	RISER
DIA	DIAMETER	REC	RECOMMENDED
DIM	DIMENSION	REF	REFERENCE
DISP	DISPENSER	REFR	REFRIGERATOR
DN	DOWN	REINF	REINFORCED
DS	DOWN SPOUT	REQD	REQUIRED
DW	DISHWASHER	RET	RETAINING
DWG	DRAWING	R O	ROUGH OPENING
E	EAST	S	SOUTH
EA	EACH	SC	SOLID CORE
EL	ELEVATION	SCHED	SCHEDULE
ELEV	ELEVATOR	SCWD	SOLID CORE WOOD
ENGR	ENGINEER	SF	SQUARE FEET, SQUARE FOOT
EQ	EQUAL	SG	SAFETY GLAZING
EQUIP	EQUIPMENT	SHTG	SHEATHING
EQUIV	EQUIVALENT	SIM	SIMILAR
EXP	EXPANSION, EXPOSED	SPEC	SPECIFICATION
(E), EXST	EXISTING	SQ	SQUARE
EXT	EXTERIOR	SS	STAINLESS STEEL
FAB	FABRICATE	STD	STANDARD
FD	FLOOR DRAIN	STL	STEEL
FDN	FOUNDATION	STOR	STORAGE
FE	FIRE EXTINGUISHER	STRUCT	STRUCTURAL
FEC	FIRE EXTINGUISHER CABINET	T	TEMPERED SAFETY GLASS
FF	FINISH FLOOR	T&B	TOP AND BOTTOM
FIN	FINISH	TEMP	TEMPORARY
FLR	FLOOR	T&G	TONGUE AND GROOVE
FT	FEET, FOOT	THRU	THROUGH
FTG	FOOTING	T/O	TOP OF
FUR	FURRING, FURRED	TOM	TOP OF MASONRY
FV	FIELD VERIFY	TOS	TOP OF STEEL
GA	GAUGE	TOSL	TOP OF SLAB
GALV	GALVANIZED	TOW	TOP OF WALL
GC	GENERAL CONTRACTOR	TYP	TYPICAL
GL	GLASS, GLAZING	UNO	UNLESS NOTED OTHERWISE
GRT	GROUT	VERT	VERTICAL
GWB	GYPSPUM WALL BOARD	VTO	VENT TO OUTSIDE
HB	HOSE BIB	VTR	VENT THROUGH ROOF
HD	HEAD	W	WEST
HDWD	HARDWOOD	W/	WITH
HDR	HEADER	W/O	WITHOUT
HM	HOLLOW METAL	WND	WINDOW
HORIZ	HORIZONTAL	WD	WOOD
HR	HOUR	W/R	WATER RESISTANT
HT	HEIGHT	WWF	WELDED WIRE FABRIC

GENERAL PLAN NOTES:

- 1) REFER TO SHEET A5.0 FOR WALL, FLOOR AND ROOF ASSEMBLY TYPES
- 2) ALL DIMENSIONS ARE TO FACE OF STUD OR FACE OF CONCRETE UNLESS OTHERWISE NOTED
- 3) INTERIOR DOORS TO BE INSTALLED 4-1/2" FROM FACE OF STUD TO EDGE OF ROUGH OPENING IF NOT DIMENSIONED
- 4) ALL WINDOW DIMENSIONS ARE TO ROUGH OPENING
- 5) REFER TO STRUCTURAL DOCUMENTS FOR ALL CONCRETE & FRAMING INFORMATION

GENERAL CONSTRUCTION NOTES:

- 1) THE CONTRACTOR SHALL CAREFULLY STUDY AND COMPARE THE CONTRACT DOCUMENTS WITH EACH OTHER AND WITH INFORMATION FURNISHED BY THE OWNER AND SHALL AT ONCE REPORT TO THE ARCHITECT ERRORS, INCONSISTENCIES OR OMISSIONS DISCOVERED. IF THE CONTRACTOR PERFORMS ANY CONSTRUCTION ACTIVITY KNOWING IT INVOLVES A RECOGNIZED ERROR, INCONSISTENCY OR OMISSION IN THE CONTRACT DOCUMENTS WITHOUT SUCH NOTICE TO THE ARCHITECT, THE CONTRACTOR SHALL ASSUME APPROPRIATE RESPONSIBILITY FOR SUCH PERFORMANCE AND SHALL BEAR AN APPROPRIATE AMOUNT OF THE ATTRIBUTABLE COSTS FOR CORRECTION.
- 2) BEFORE ORDERING MATERIALS OR DOING ANY WORK, THE GENERAL CONTRACTOR AND ALL OF THE SUB-CONTRACTORS SHALL VERIFY ALL MEASUREMENTS ON THE DRAWINGS AND AT THE CONSTRUCTION SITE, AND SHALL BE RESPONSIBLE FOR THEIR CORRECTNESS. NO EXTRA COMPENSATION WILL BE ALLOWED ON ACCOUNT OF DIFFERENCES BETWEEN ACTUAL DIMENSIONS AND THOSE INDICATED ON THE DRAWINGS. ANY DISCOVERED DIFFERENCES SHALL BE REPORTED TO THE ARCHITECTS FOR DESIGN CONSIDERATIONS **BEFORE** PROCEEDING FURTHER WITH THE WORK. THE CONTRACTOR IS HEREBY ADVISED THAT THE DRAWINGS ARE NOT TO SCALE.
- 3) WORK SHALL CONFORM TO APPLICABLE CODES AND REGULATIONS OF AGENCIES HAVING JURISDICTION.
- 4) CONTRACTOR SHALL KEEP ALL AREAS UNDER CONSTRUCTION CLEAR OF DIRT AND DEBRIS.
- 5) CONTRACTOR SHALL REPAIR DAMAGED SURFACES WHICH WERE DAMAGED BY CONSTRUCTION OR CLEAN-UP, AND CORRECT CONDITIONS TO MATCH SURROUNDING FINISHED CONDITIONS.
- 6) REPETITIVE FEATURES NOT NOTED ON THE DRAWINGS SHALL BE COMPLETELY PROVIDED AS DRAWN IN FULL.
- 7) DIMENSIONS ON DRAWINGS ARE TAKEN TO THE FACE OF CONCRETE AND TO THE FACE OF STUD, UNLESS OTHERWISE NOTED. FIELD VERIFY ALL DIMENSIONS.
- 8) FIELD VERIFY MILLWORK DIMENSIONS AND ALL WINDOW AND DOOR DIMENSIONS.
- 9) PROTECT ALL PORTIONS OF THE EXISTING BUILDING OR SITE NOT SCHEDULED TO BE REMOVED, IF APPLICABLE, AND REPLACE OR REPAIR ALL SUCH ITEMS DAMAGED DURING CONSTRUCTION. PROVIDE PROTECTION AGAINST INCLEMENT WEATHER, WIND, FROST, EXCESSIVE HEAT, VANDALISM, AND ALL WORKERS, DELIVERY PERSONNEL, SUB-CONTRACTORS AND BUILDING INSPECTORS SO AS TO MAINTAIN ALL WORK, MATERIAL, APPARATUS AND FIXTURES FREE FROM DAMAGE, INCLUDING SURFACE SCRATCHES AND BLEMISHES. ALL NEW AND EXISTING WORK LIKELY TO BE DAMAGED SHALL BE APPROPRIATELY COVERED OR PROTECTED AT ALL TIMES. PROTECT ALL PLANTING AREAS FROM FOOT OR WHEEL TRAFFIC, AND AVOID CRUSHING SAME DUE TO STORED MATERIALS.

SYMBOLS:

	WINDOW TYPE
	EXTERIOR DOOR TYPE
	DOOR TYPE
	ASSEMBLY TYPE
	SECTION CALL OUT
	SMOKE DETECTOR
	CARBON MONOXIDE DETECTOR
	100 CFM FAN
	DOWNSPOUT
	FLOOR DRAIN
	HOSE BIB

PROJECT:
LOUDEN RESIDENCE
3315 97TH AVE SE
MERCER ISLAND, WA

ISSUE:
PERMIT SET 2020-04-13

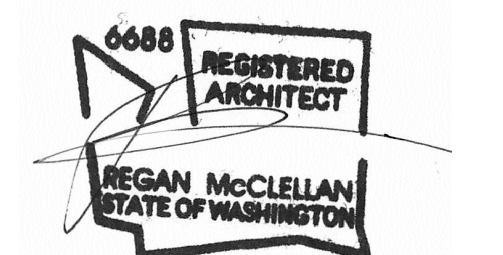

DATE:
MARCH 13, 2020

SHEET TITLE:

GENERAL CONDITIONS +
ABBREVIATIONS

SHEET:

G0.1

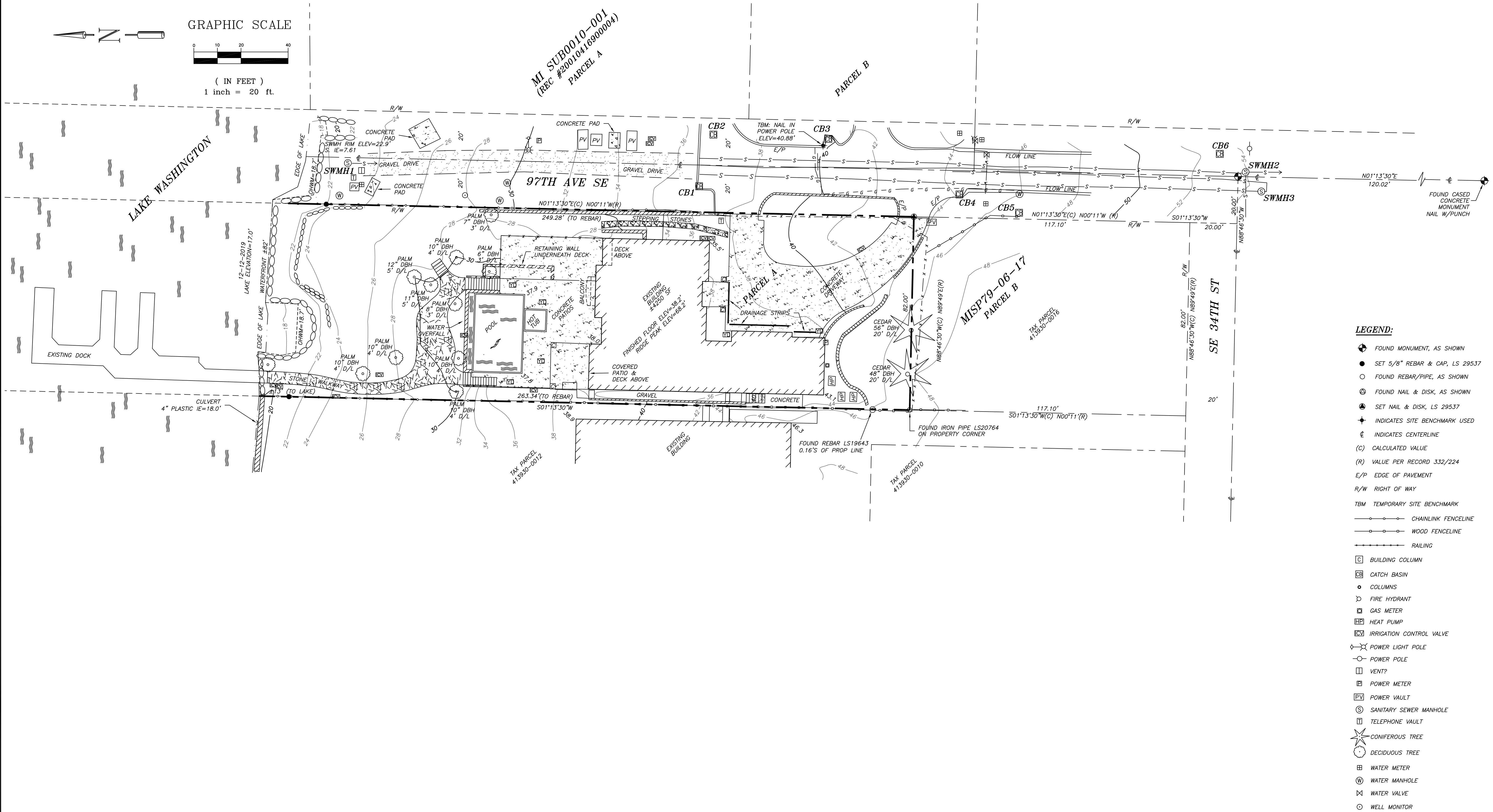
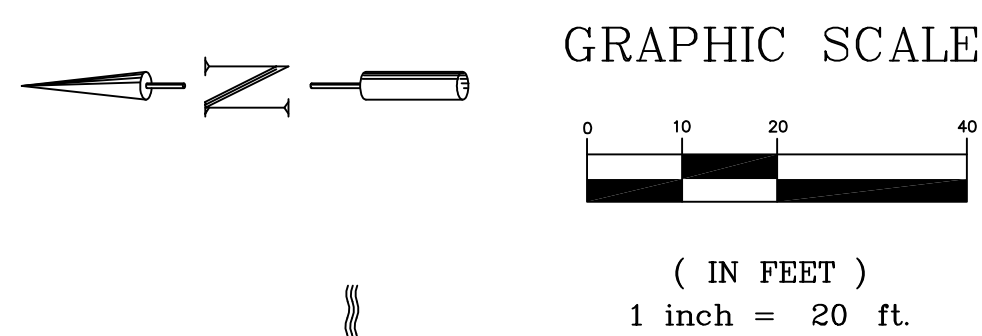

- LEGEND:**
- ◆ FOUND MONUMENT, AS SHOWN
 - SET 5/8" REBAR & CAP, LS 29537
 - FOUND REBAR/PIPE, AS SHOWN
 - ⊙ FOUND NAIL & DISK, AS SHOWN
 - ⊕ SET NAIL & DISK, LS 29537
 - ⊕ INDICATES SITE BENCHMARK USED
 - ⊕ INDICATES CENTERLINE
 - (C) CALCULATED VALUE
 - (R) VALUE PER RECORD 332/224
 - E/P EDGE OF PAVEMENT
 - R/W RIGHT OF WAY
 - TBM TEMPORARY SITE BENCHMARK
 - CHAINLINK FENCELINE
 - WOOD FENCELINE
 - RAILING
 - BUILDING COLUMN
 - CB CATCH BASIN
 - COLUMNS
 - ⊕ FIRE HYDRANT
 - ⊕ GAS METER
 - ⊕ HEAT PUMP
 - ⊕ IRRIGATION CONTROL VALVE
 - ⊕ POWER LIGHT POLE
 - POWER POLE
 - VENT?
 - ⊕ POWER METER
 - PV POWER VAULT
 - ⊕ SANITARY SEWER MANHOLE
 - ⊕ TELEPHONE VAULT
 - ★ CONIFEROUS TREE
 - DECIDUOUS TREE
 - ⊕ WATER METER
 - ⊕ WATER MANHOLE
 - ⊕ WATER VALVE
 - WELL MONITOR
 - GAS LINE
 - SANITARY/SEWER LINE
 - D STORM/DRAINAGE LINE
 - W WATER UTILITY LINE

STORM:

CB1
N. 12" STEEL IE=34.0'
S. 12" CONCRETE IE=34.8'
E. 12" CONCRETE IE=33.8'

CB2 RIM ELEV=36.1'
N. 12" STEEL IE=34.5'
S. 4" PVC IE=34.5'
W. 12" STEEL IE=34.2'

CB3 RIM ELEV=39.6'
N. 12" CONCRETE IE=37.9'
S. 12" CONCRETE IE=38.3'
E. 4" PVC IE=38.0'

CB4 RIM ELEV=44.0'
N. 12" CONCRETE IE=42.0'
S. 12" CONCRETE IE=42.2'
W. 4" PVC IE=42.6'
W. 12" STEEL IE=42.6'

CB5 RIM ELEV=46.9'
N. 12" CONCRETE IE=45.0'
E. 6" PVC IE=44.9'
S. 12" STEEL IE=44.9'

CB6 RIM ELEV=52.6'
N. 12" STEEL IE=50.5'
S. 12" STEEL IE=50.3'

SEWER:

SWMH1 RIM ELEV=22.9'
S. 12" STEEL IE=7.6'

SWMH2 RIM ELEV=53.9'
N. 12" STEEL IE=44.1'
S. 12" STEEL IE=44.6'
W. 12" STEEL IE=44.2'

SWMH3 RIM ELEV=54.5'
CONTAINS WOOD BOX

LEGAL DESCRIPTION:
LOT A OF CITY OF MERCER ISLAND SHORT PLAT NO. MI 79-06-17, RECORDED UNDER RECORDING NO. 7909100629, RECORDS OF KING COUNTY, WASHINGTON.
TOGETHER WITH SHORELANDS OF THE SECOND CLASS.
SITUATE IN THE COUNTY OF KING, STATE OF WASHINGTON.

NOTES:
FIELD MEASUREMENTS FOR THIS SURVEY PERFORMED WITH A 2" TOPCON TOTAL STATION USING TRAVERSE METHODS AND TOPCON GR5 GPS EQUIPMENT THAT MEET OR EXCEED ACCURACY REQUIREMENTS CONTAINED IN WAC 332.130.090.
THIS SURVEY WAS CONDUCTED WITHOUT THE BENEFIT OF A CURRENT TITLE REPORT AND THEREFORE DOES NOT PURPORT TO SHOW ALL EASEMENTS OR RESTRICTIONS OF RECORD, IF ANY.
THE BOUNDARY CORNERS AND LINES DEPICTED ON THIS MAP ARE PER RECORD TITLE INFORMATION AND REPRESENT DEED LINES ONLY. THEY DO NOT PURPORT TO SHOW OWNERSHIP LINES THAT MAY OTHERWISE BE DETERMINED BY A COURT OF LAW.
THIS TOPOGRAPHIC SURVEY IS INTENDED FOR GENERAL DESIGN PURPOSES. ADDITIONAL SURVEYING MAY BE REQUIRED TO MEET SPECIFIC CITY/COUNTY AND/OR ENGINEERING REQUIREMENTS.
THIS SURVEY WAS PREPARED FOR THE EXCLUSIVE USE OF THE CLIENT NAMED HEREIN, TO BE USED ONLY FOR THE PURPOSE FOR WHICH IT WAS ORIGINALLY INTENDED. ITS USE DOES NOT EXTEND TO, AND IS NOT AUTHORIZED FOR USE BY ANY UNNAMED PERSON OR PERSONS. THIS SURVEY IS NOT TRANSFERABLE TO ANY OTHER PARTY WITHOUT THE EXPRESS PERMISSION AND RECERTIFICATION BY THIS SURVEYOR TO ANOTHER PARTY.
ALL FOUND SURVEY EVIDENCE WAS VISITED ON THE DATE OF THIS SURVEY UNLESS OTHERWISE NOTED.
COPYRIGHT BY CRONES SURVEYING, INC.

SITE ADDRESS:
3315 98TH AVE SE
MERCER ISLAND, WA 98040

SURVEYOR'S CERTIFICATE
THIS MAP CORRECTLY REPRESENTS A SURVEY MADE BY ME OR UNDER MY DIRECTION, AT THE REQUEST OF REGAN MCCLELLAN, IN DECEMBER, 2019.

JAMES D. CRONES
L.S. 29537

James D. Cronos

DATE: 1-21-20

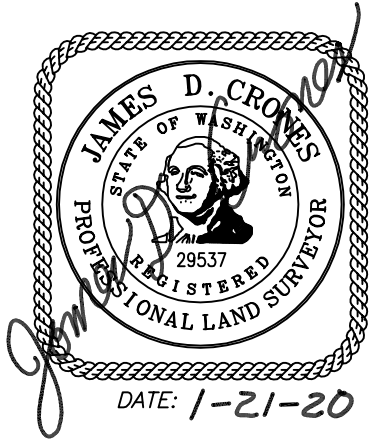

Revisions

1/22/2020	ADDED OHM LINE

Drawing Date	JANUARY 15, 2020
Scale	1" = 20'
Surveyed	DB/BE
Drawn	JB
Checked	JJC
Filename	MCCLR-02A-TOPO.DWG
SHEET	1 of 1

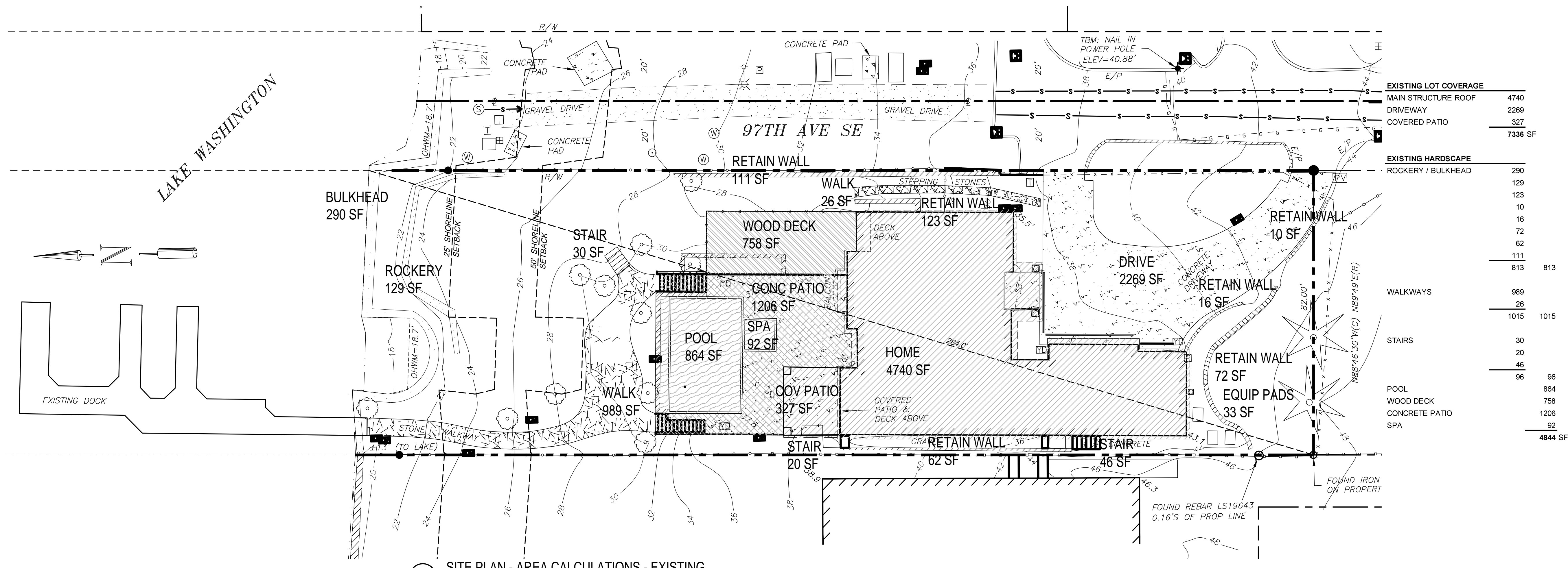

1 SITE PLAN - AREA CALCULATIONS - EXISTING
1/16"=1'-0"

EXISTING LOT COVERAGE	
MAIN STRUCTURE ROOF	4740
DRIVEWAY	2269
COVERED PATIO	327
TOTAL	7336 SF

EXISTING HARDSCAPE	
ROCKERY / BULKHEAD	290
	129
	123
	10
	16
	72
	62
	111
	813
TOTAL	813

WALKWAYS	
	989
	26
TOTAL	1015

STAIRS	
	30
	20
	46
TOTAL	96

POOL	
	864
WOOD DECK	758
CONCRETE PATIO	1206
SPA	92
TOTAL	4844 SF

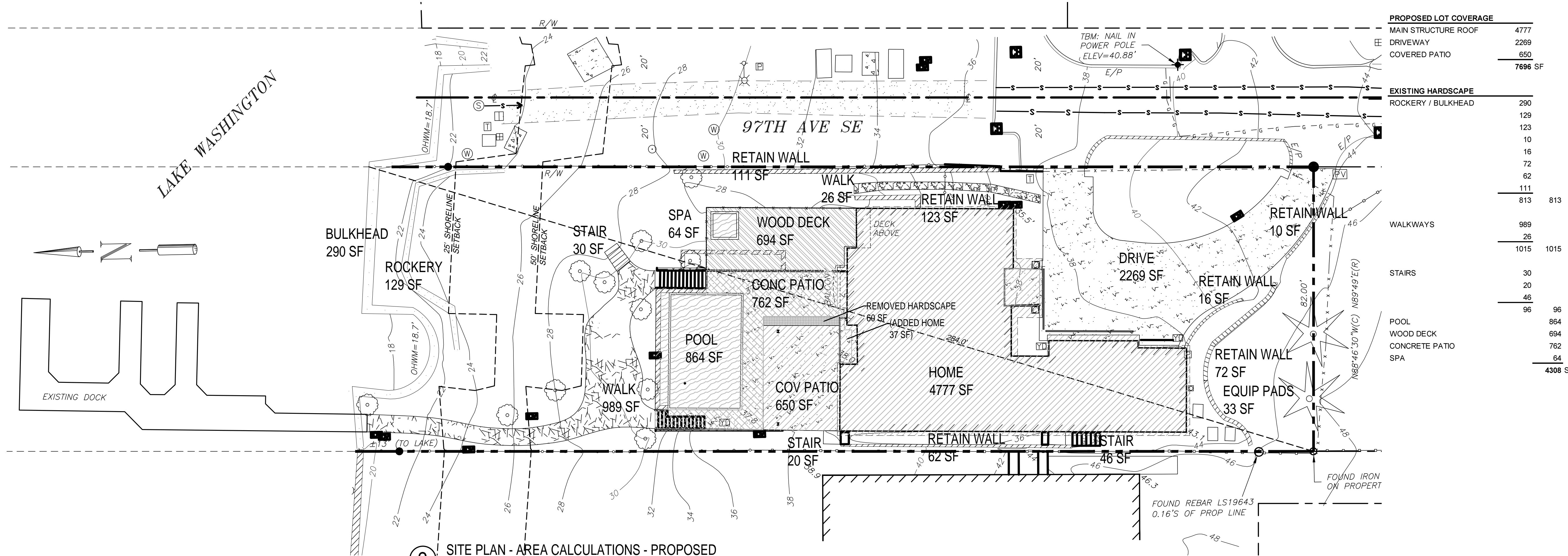

2 SITE PLAN - AREA CALCULATIONS - PROPOSED
1/16"=1'-0"

PROPOSED LOT COVERAGE	
MAIN STRUCTURE ROOF	4777
DRIVEWAY	2269
COVERED PATIO	650
TOTAL	7696 SF

EXISTING HARDSCAPE	
ROCKERY / BULKHEAD	290
	129
	123
	10
	16
	72
	62
	111
	813
TOTAL	813

WALKWAYS	
	989
	26
TOTAL	1015

STAIRS	
	30
	20
	46
TOTAL	96

POOL	
	864
WOOD DECK	694
CONCRETE PATIO	762
SPA	64
TOTAL	4308 SF

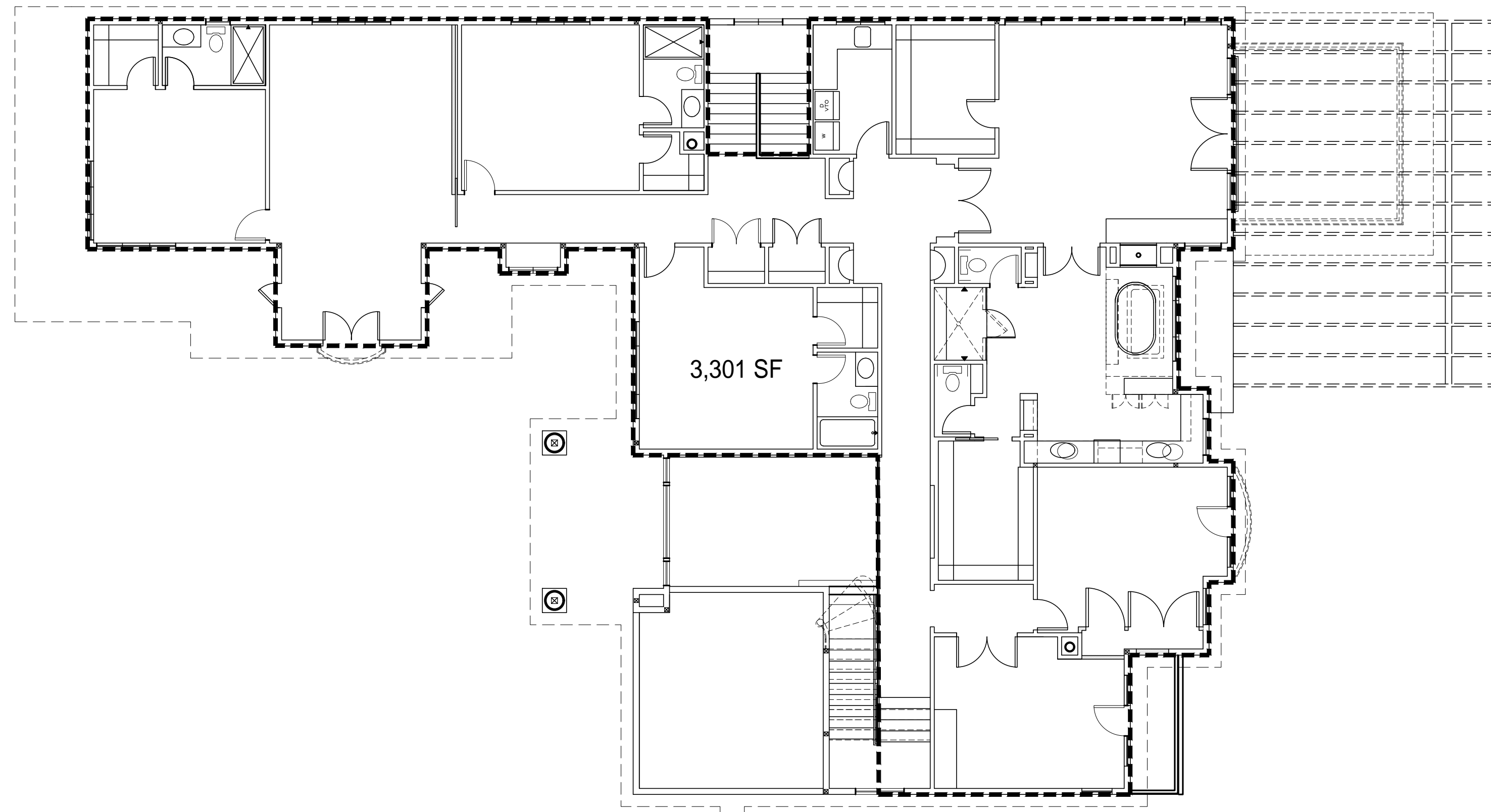

1 SECOND FLOOR PLAN - PROPOSED W/ DEMO
1/8"=1'-0"

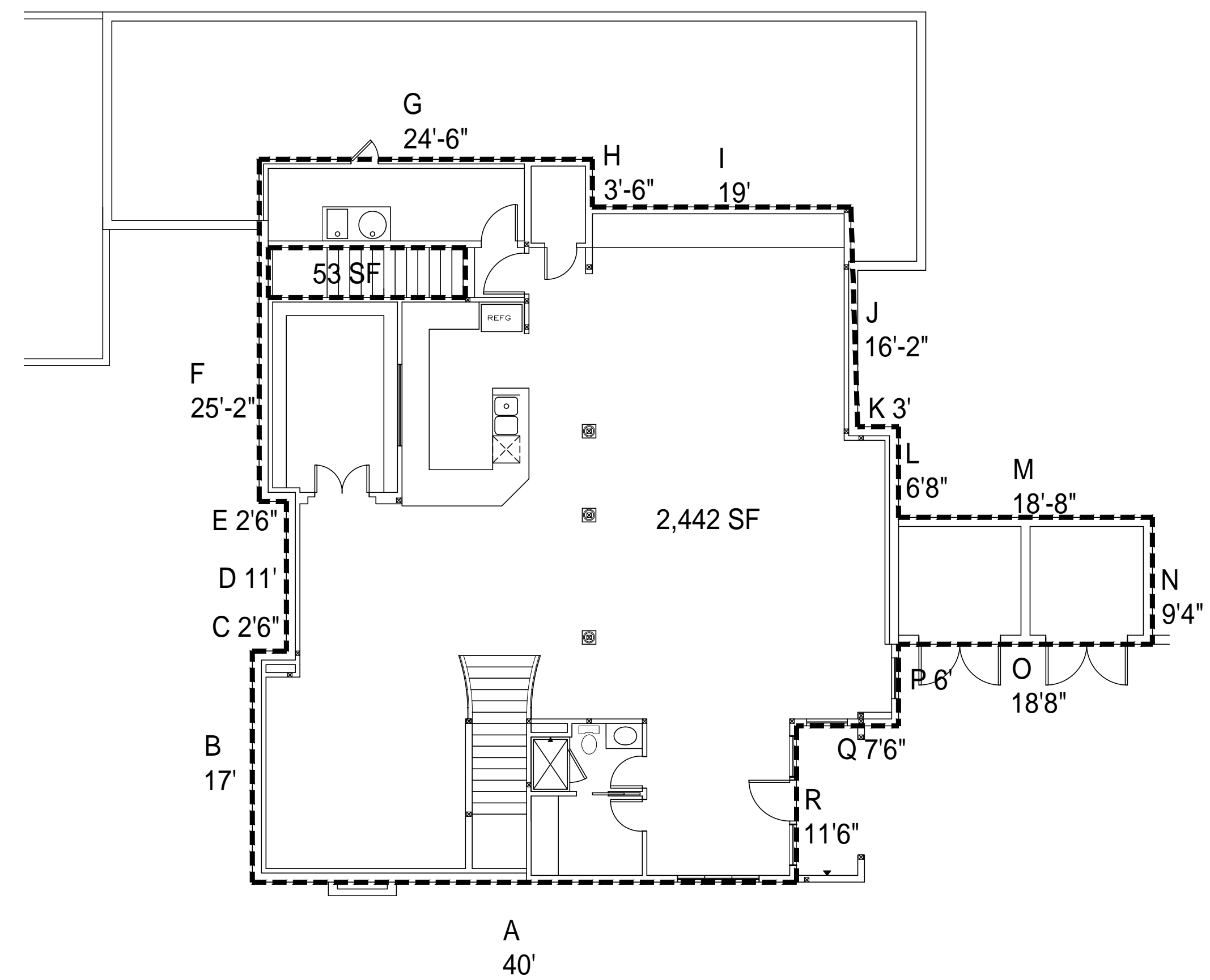

2 BASEMENT PLAN - EXISTING
1/8"=1'-0"

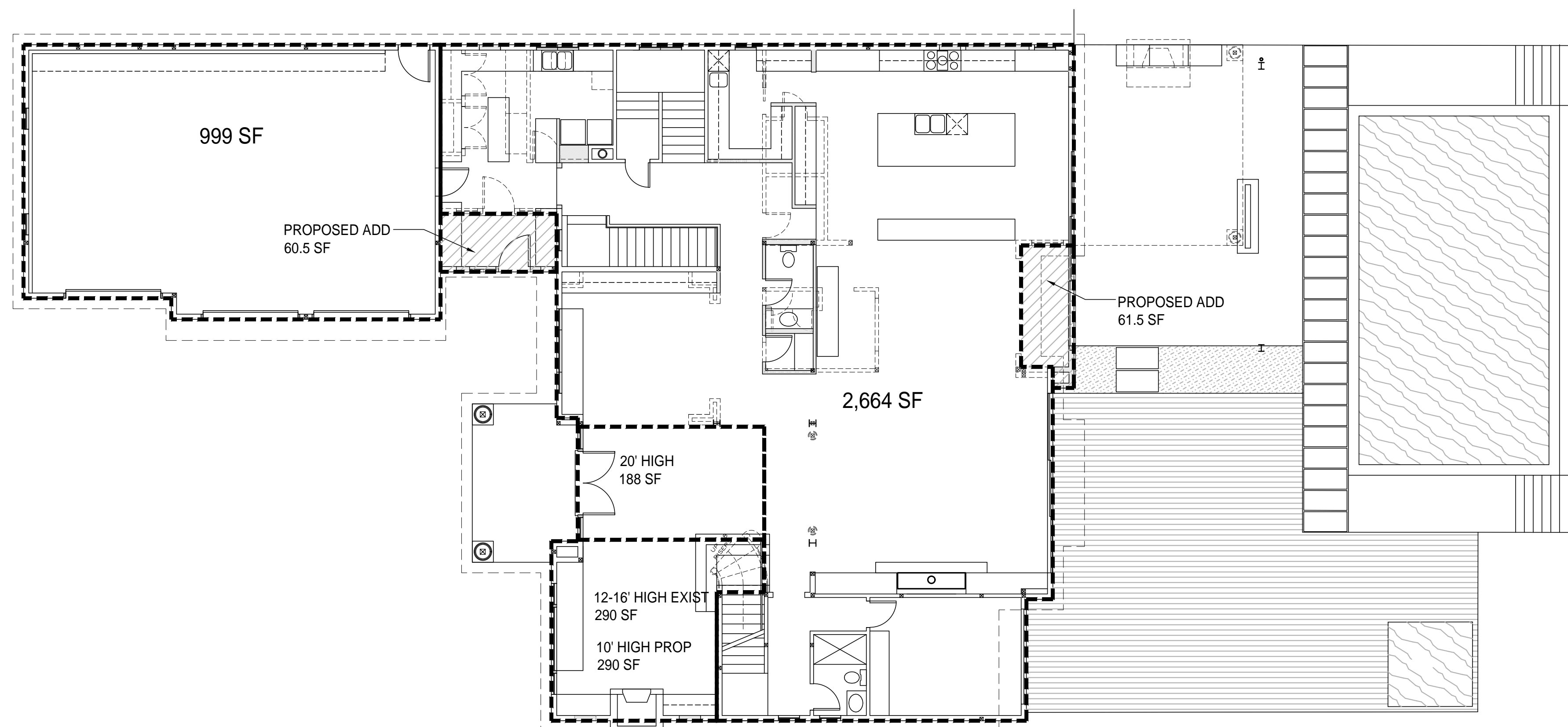

3 FIRST FLOOR PLAN - PROPOSED W/ DEMO
1/8"=1'-0"

BASEMENT - GROSS SQUARE FEET CALC

WALL	LENGTH	COVERAGE	TOTAL
A	40	47%	18.8
B	17	100%	17
C	2.5	100%	2.5
D	11	100%	11
E	2.5	100%	2.5
F	25.17	100%	25.17
G	24.5	100%	24.5
H	3.5	100%	3.5
I	19	100%	19
J	16.17	100%	16.17
K	3	100%	3
L	6.67	100%	6.67
M	18.67	100%	18.67
N	9.33	100%	9.33
O	18.67	0%	0
P	6	0%	0
Q	7.5	0%	0
R	11.5	0%	0
	242.68		177.81

	73%
BASEMENT AREA	2,442 SF
BACK STAIR	53 SF
2,389 GSF TOTAL	
1750 SF EXCLUDED	
639 GSF COUNTED	

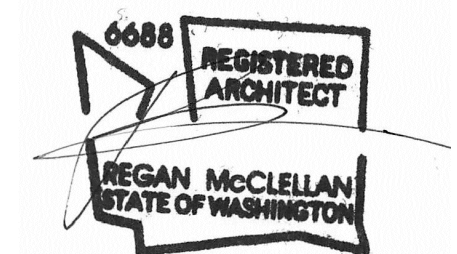

DATE:
MARCH 13, 2020

SHEET TITLE:
FLOOR AREA
CALCULATIONS

SHEET:

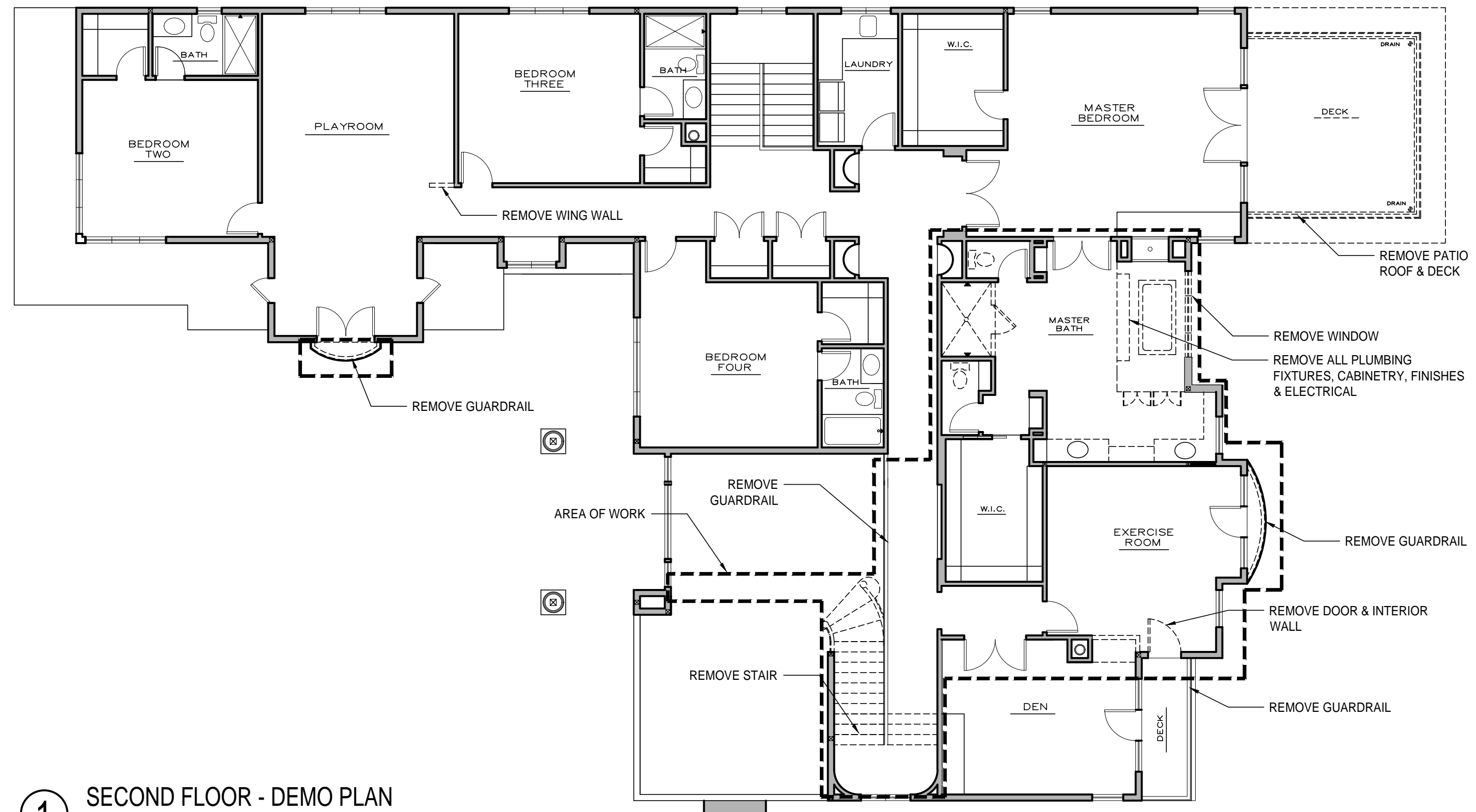

1 SECOND FLOOR - DEMO PLAN
1/8"=1'-0"

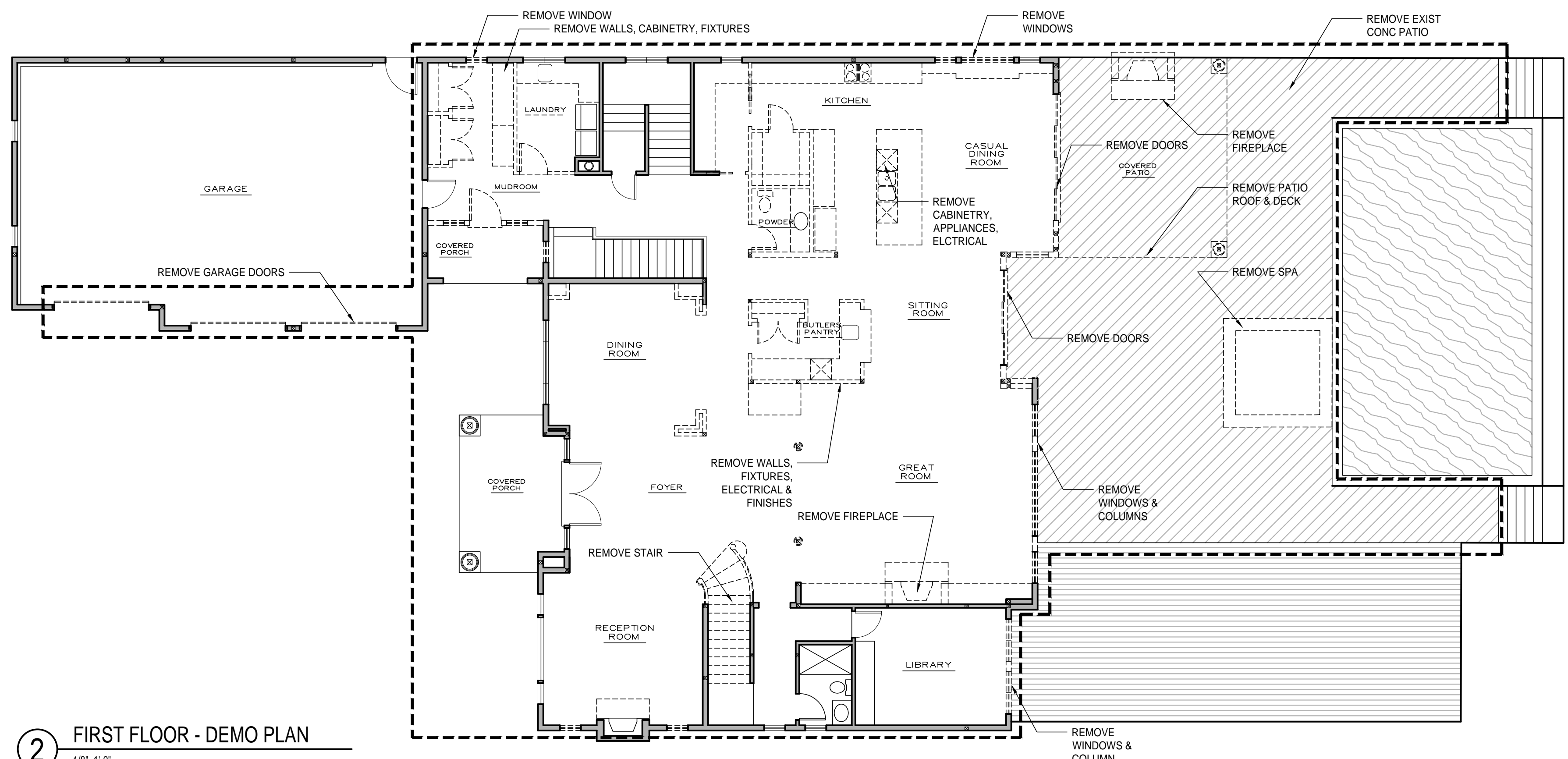

2 FIRST FLOOR - DEMO PLAN
1/8"=1'-0"

PROJECT:
LOUDEN RESIDENCE
3315 97TH AVE SE
MERCER ISLAND, WA

ISSUE:
PERMIT SET 2020-04-13

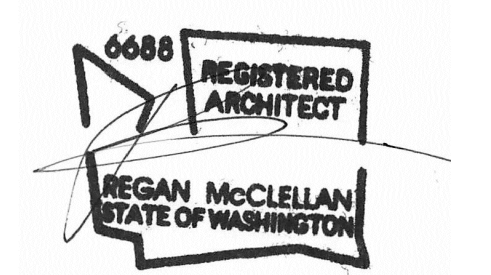

DATE:
MARCH 13, 2020

SHEET TITLE:
DEMOLITION PLANS

SHEET:

D2.0

- DEMOLITION KEY:**
- DEMOLISH
 - KEEP EXISTING
 - - - AREA OF WORK

GENERAL NOTES:

- 1) COORDINATE WITH STRUCTURAL ENGINEER BEFORE REMOVING ANY LOAD BEARING FEATURES
- 2) REMOVE HOME EXTERIOR STUCCO WALL FINISH INCLUDING DOOR & WINDOW TRIM

PROJECT:
LOUDEN RESIDENCE
3315 97TH AVE SE
MERCER ISLAND, WA

ISSUE:
PERMIT SET 2020-04-13

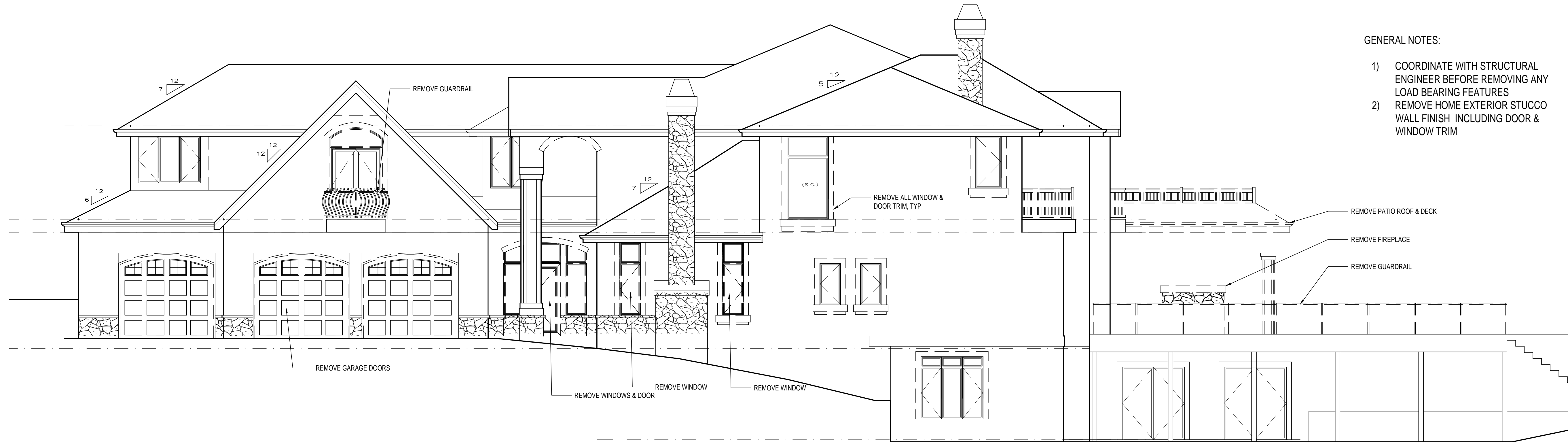

① EAST ELEVATION
3/16" = 1'-0"



② WEST ELEVATION
3/16" = 1'-0"

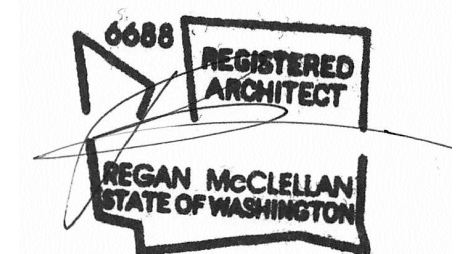

DATE:
MARCH 13, 2020

SHEET TITLE:
DEMOLITION
BUILDING ELEVATIONS

SHEET:

D3.0



- DEMOLITION KEY:**
- DEMOLISH
 - KEEP EXISTING
 - — — — AREA OF WORK

GENERAL NOTES:

- 1) COORDINATE WITH STRUCTURAL ENGINEER BEFORE REMOVING ANY LOAD BEARING FEATURES
- 2) REMOVE HOME EXTERIOR STUCCO WALL FINISH INCLUDING DOOR & WINDOW TRIM

① SOUTH ELEVATION
3/16" = 1'-0"



② NORTH ELEVATION
3/16" = 1'-0"

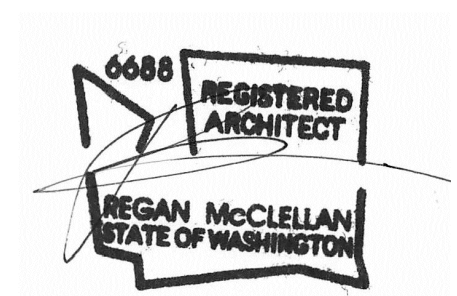

DATE:
MARCH 13, 2020

SHEET TITLE:

EXT ELEVATIONS
DEMOLITION

SHEET:

D3.1

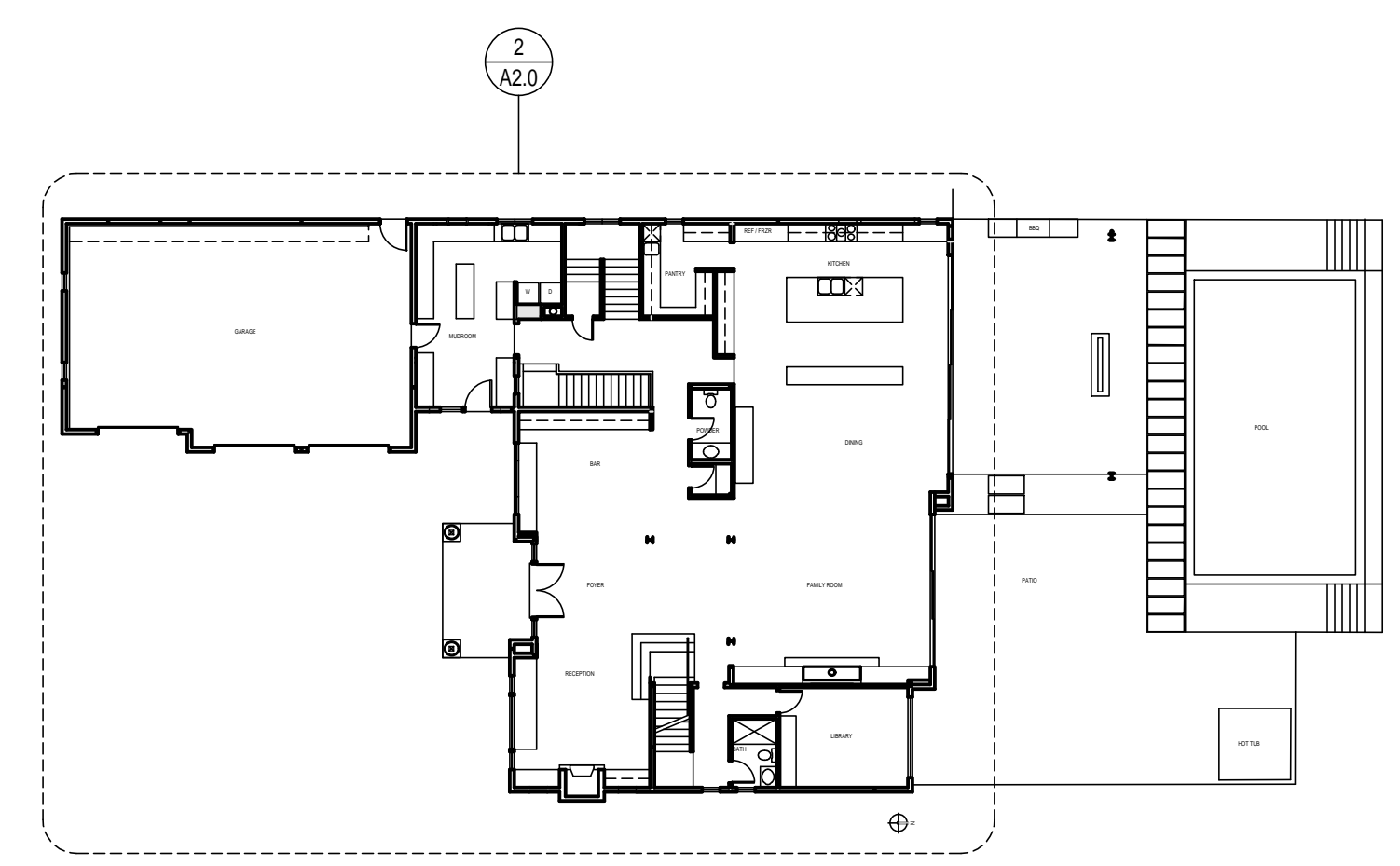
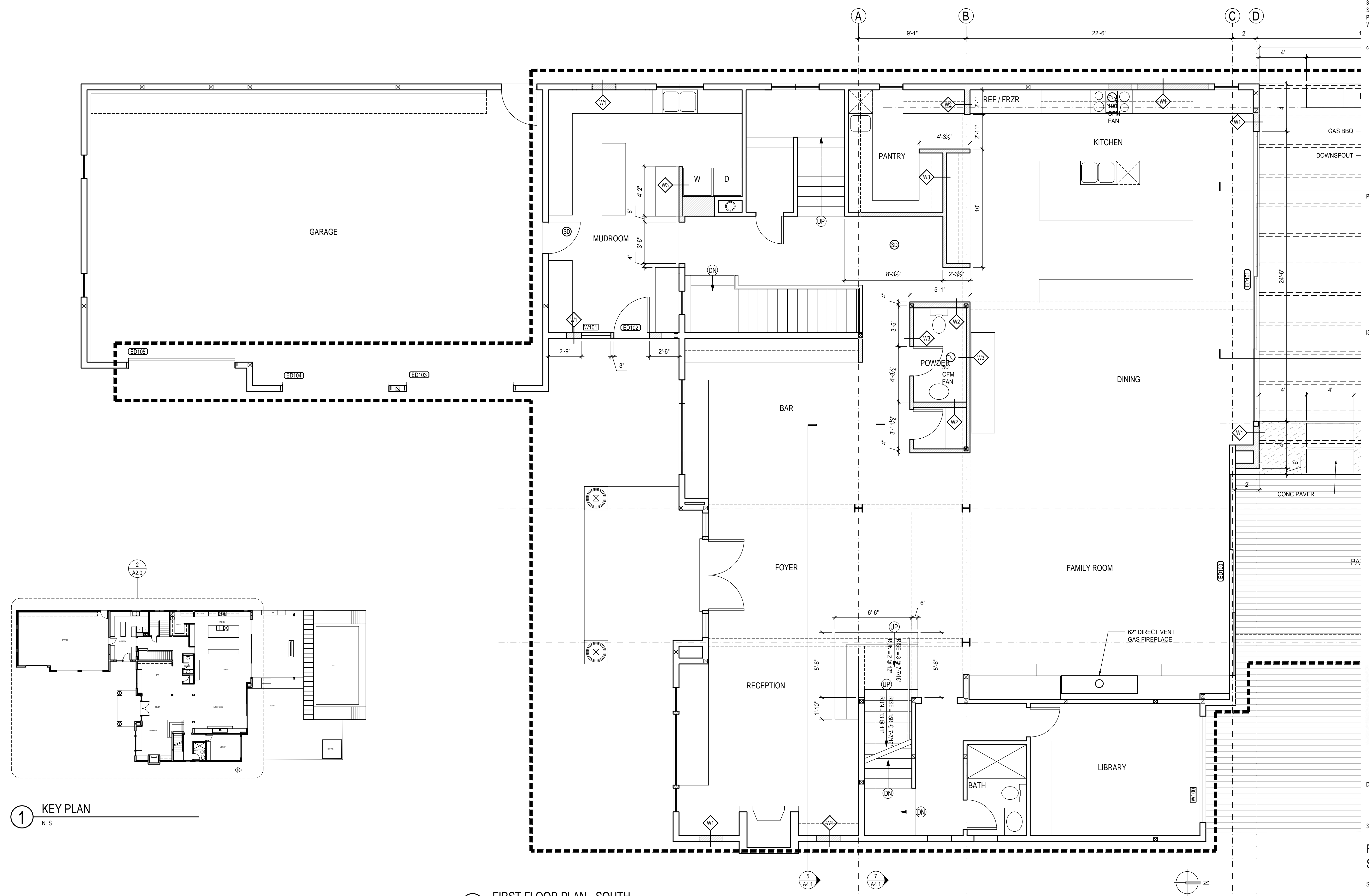
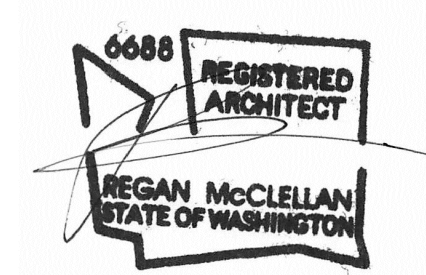

1 KEY PLAN
NTS

2 FIRST FLOOR PLAN - SOUTH
1/4"=1'-0"

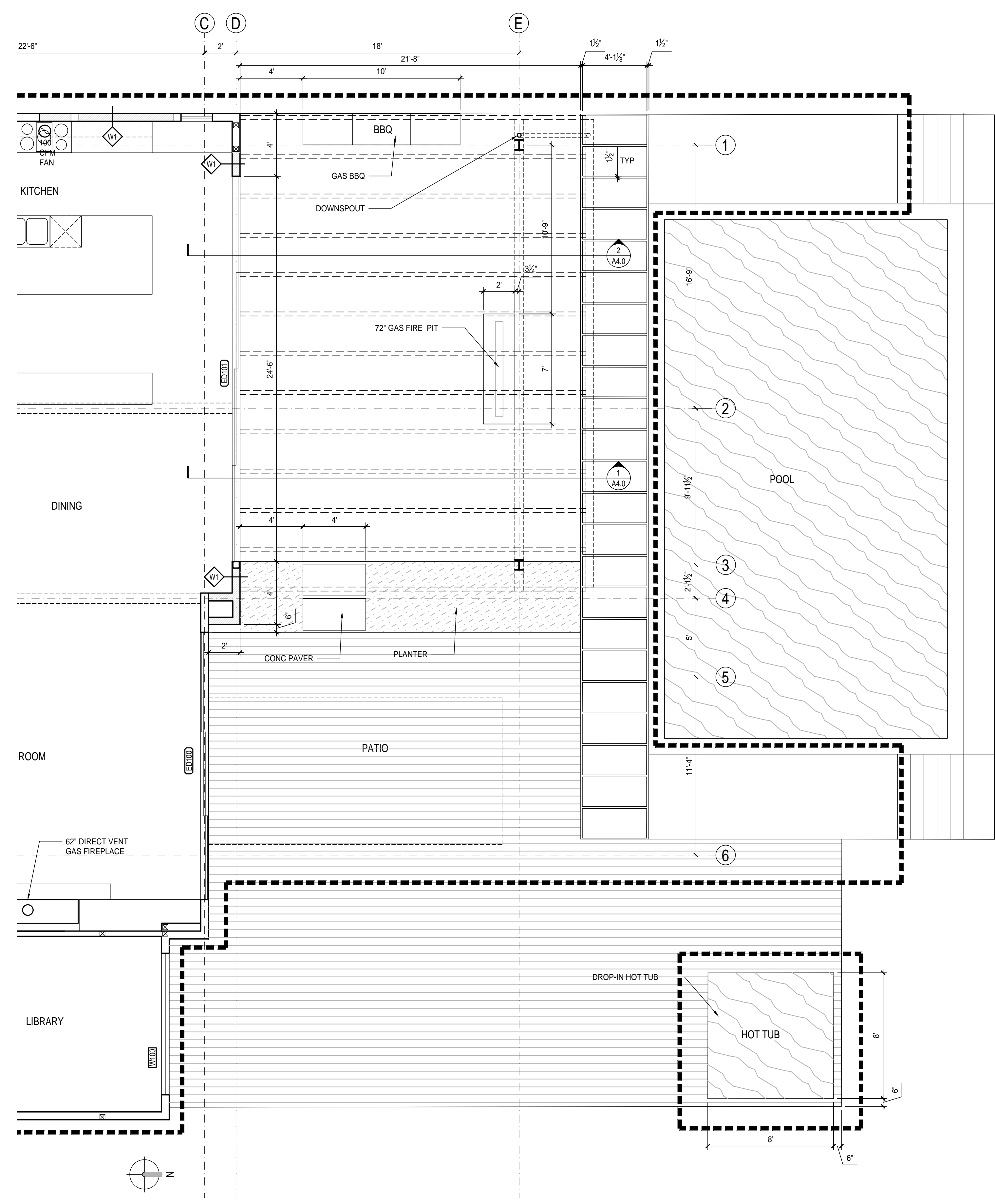

1 FIRST FLOOR PLAN - NORTH
1/4"=1'-0"

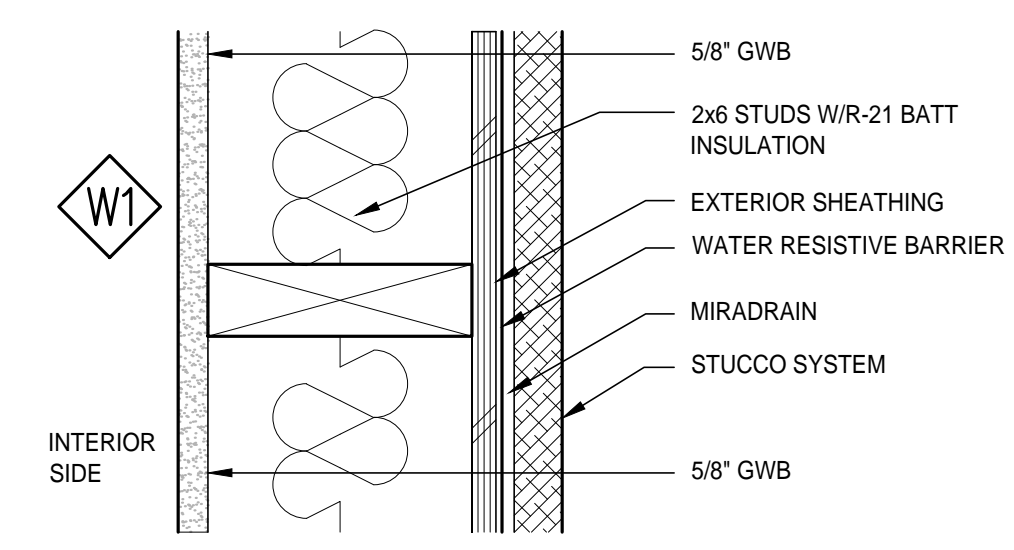

WALL ASSEMBLY: 2x6 EXT. WALL - STUCCO

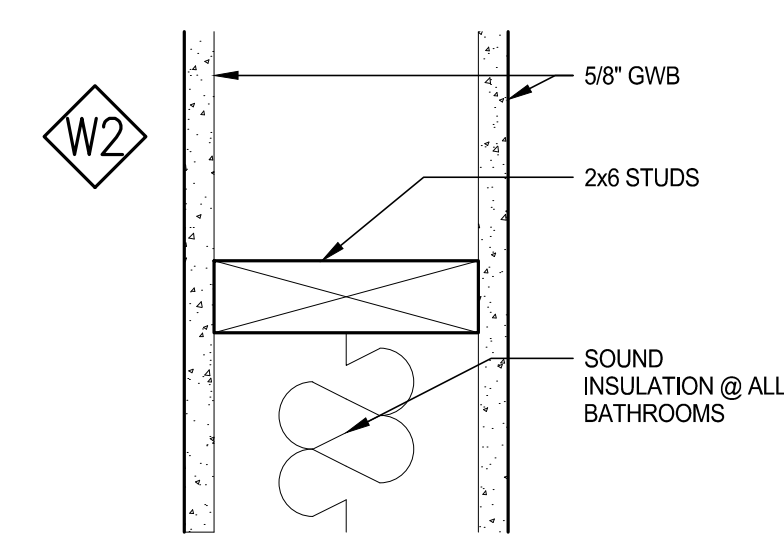

WALL ASSEMBLY: 2x6 INT. WALL
WALL ASSEMBLY: 2x6 INT. WALL, INSUL

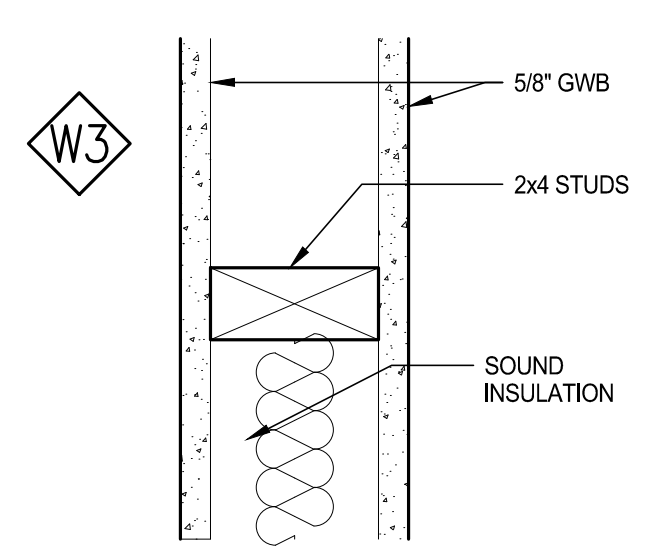

WALL ASSEMBLY: 2x4 INT. WALL
WALL ASSEMBLY: 2x4 INT. WALL, INSUL

2 ASSEMBLIES
3/8"=1'-0"

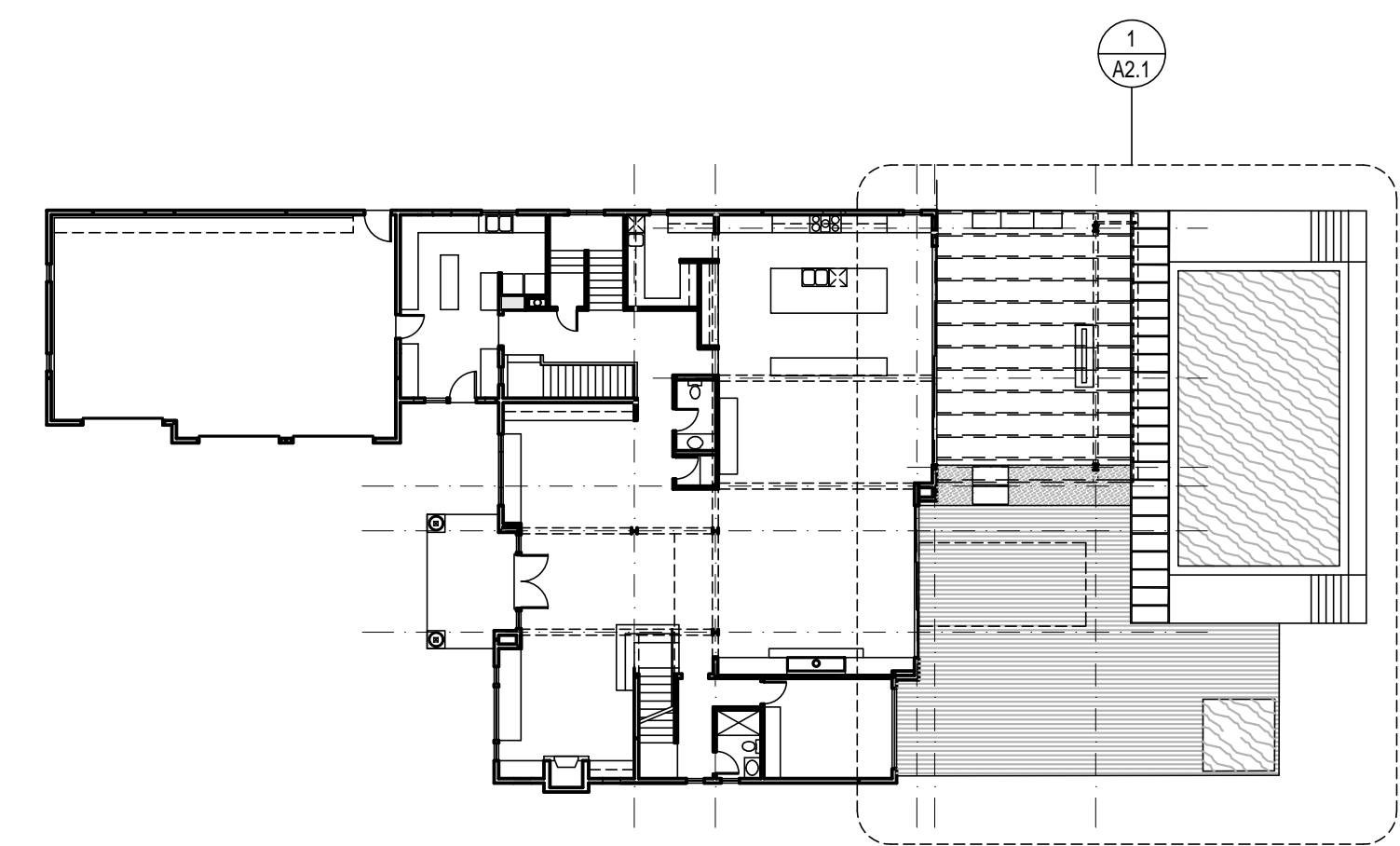

12 KEY PLAN
NTS

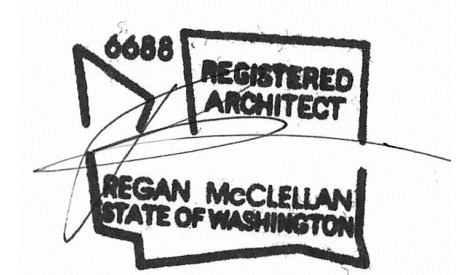

DATE:
MARCH 13, 2020

SHEET TITLE:

FIRST FLOOR PLAN
NORTH

SHEET:

A2.1

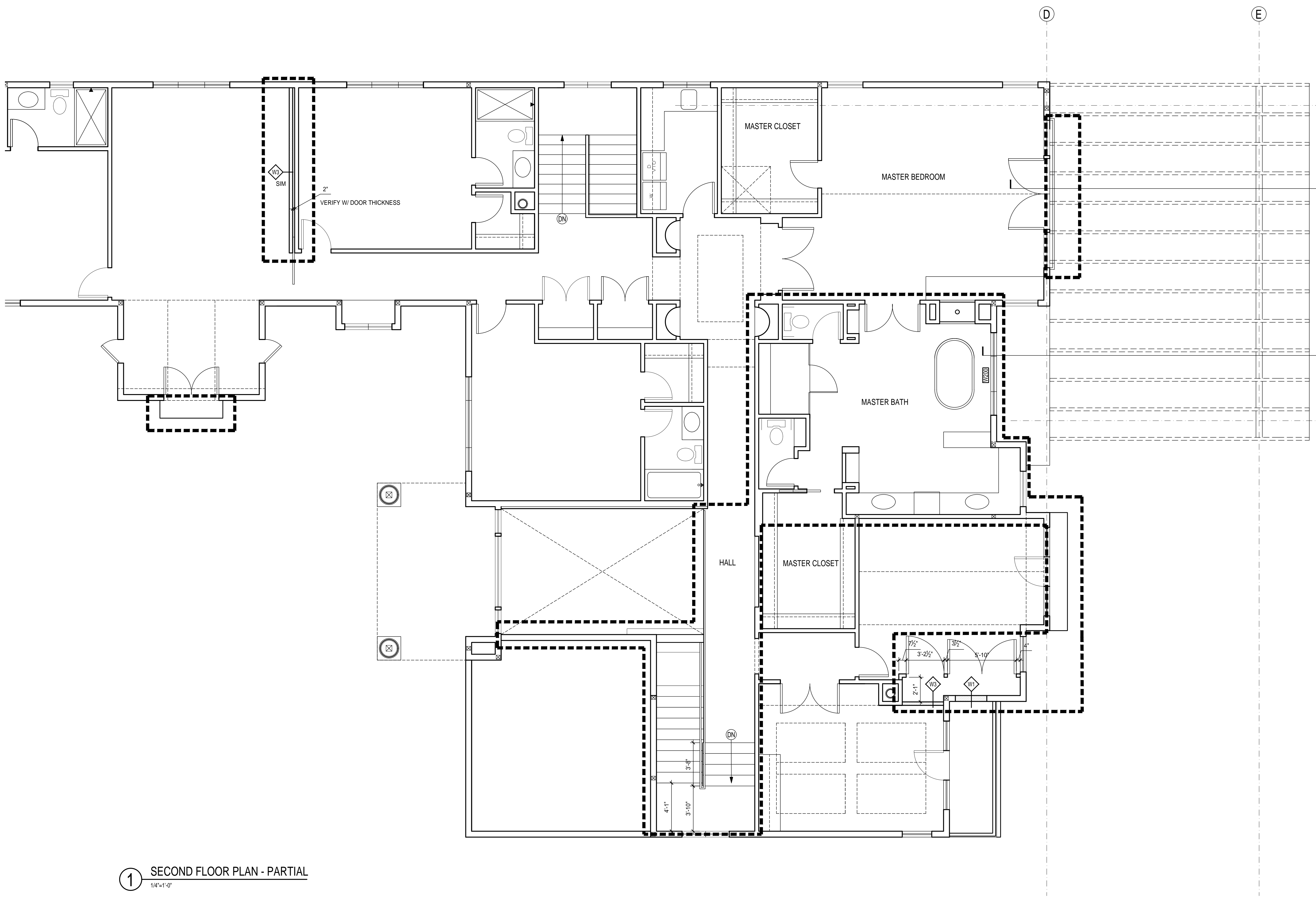

PROJECT:
LOUDEN RESIDENCE
3315 97TH AVE SE
MERCER ISLAND, WA

ISSUE:
PERMIT SET 2020-04-13

1 SECOND FLOOR PLAN - PARTIAL
1/4"=1'-0"

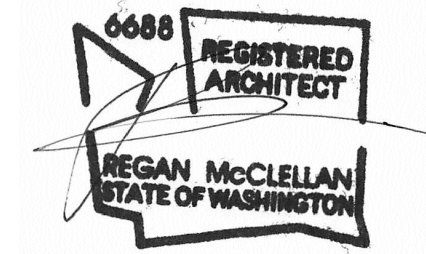

DATE:
MARCH 13, 2020

SHEET TITLE:
SECOND FLOOR
PLAN - PARTIAL

SHEET:

A2.2

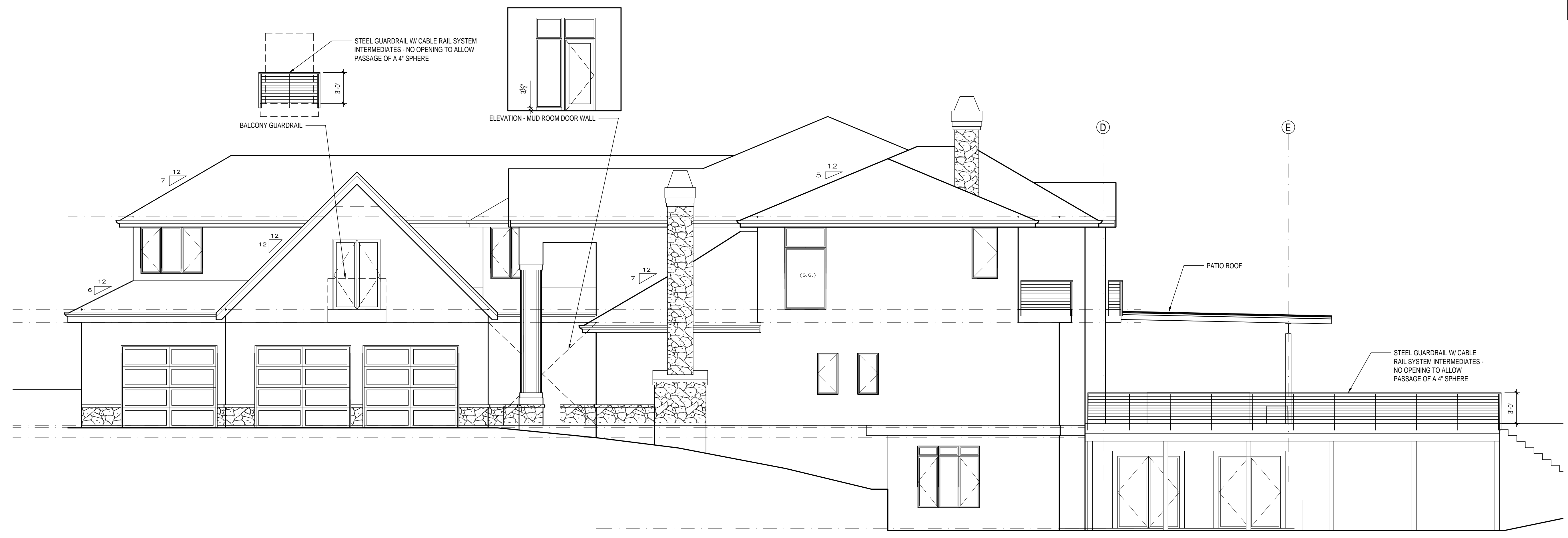

① EAST ELEVATION
3/16" = 1'-0"



② WEST ELEVATION
3/16" = 1'-0"

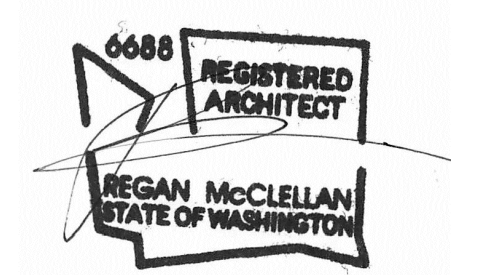

DATE:
MARCH 13, 2020

SHEET TITLE:
BUILDING ELEVATIONS

SHEET:

A3.0



1 SOUTH ELEVATION
3/16" = 1'-0"



2 NORTH ELEVATION
3/16" = 1'-0"

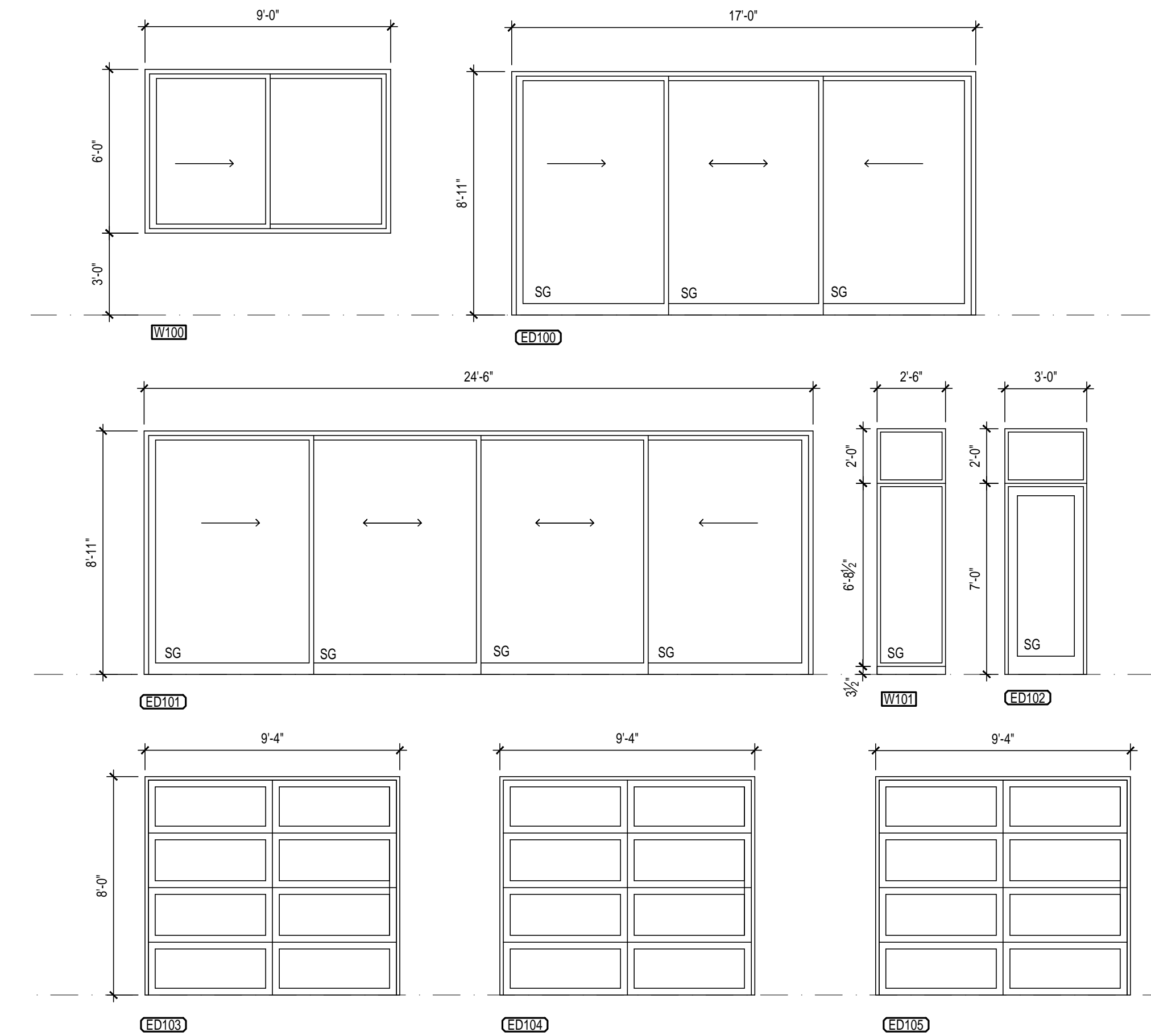

3 OPENING SCHEDULE
1/4" = 1'-0"

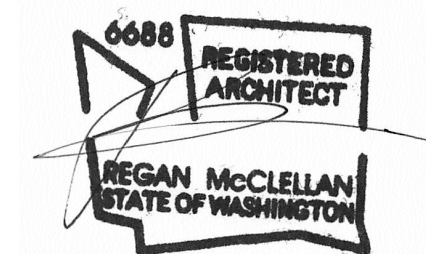

DATE:
MARCH 13, 2020

SHEET TITLE:
BUILDING ELEVATIONS
OPENING SCHEDULE

SHEET:

A3.1

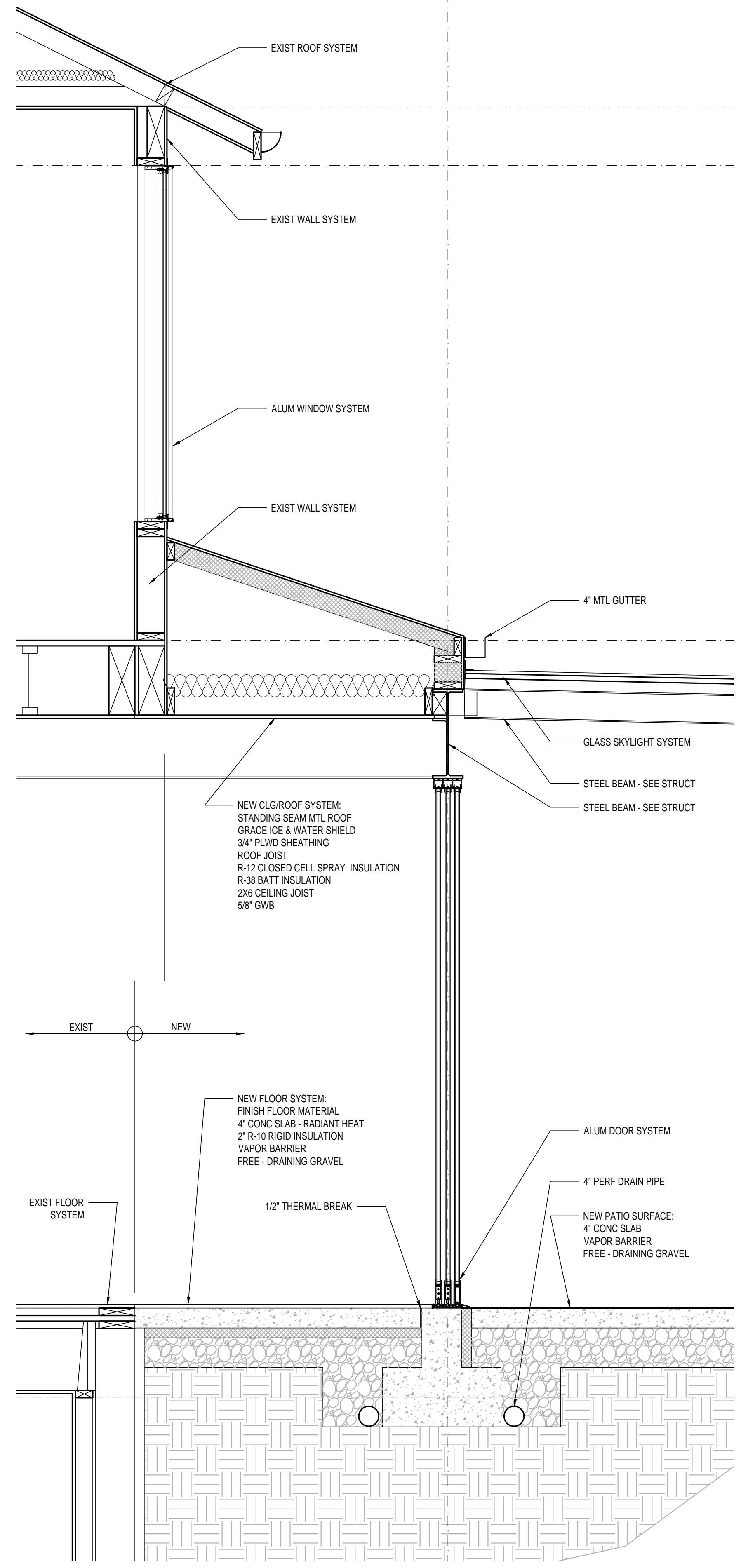

1 WALL SECTION
3/4" = 1'-0"

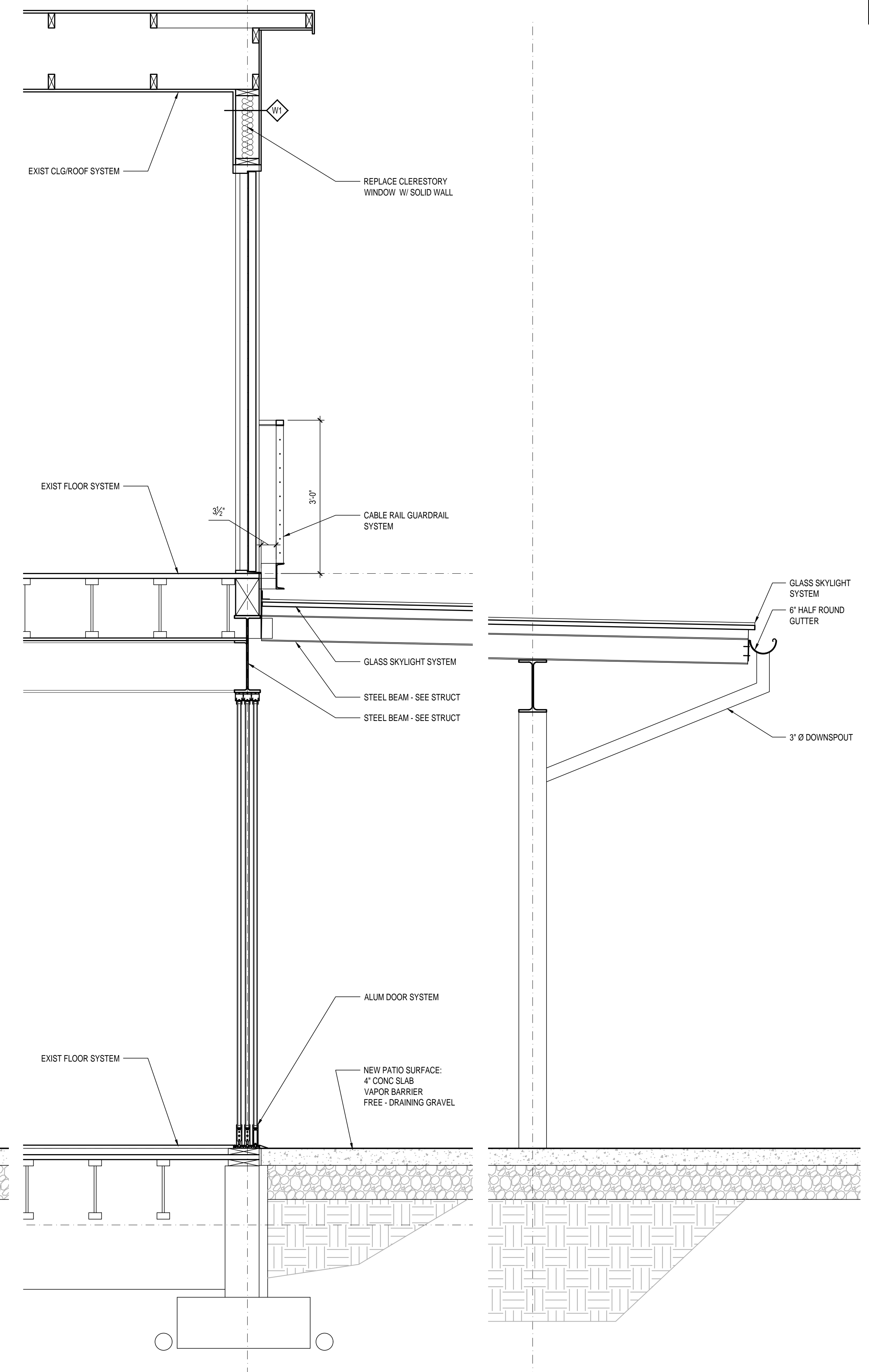
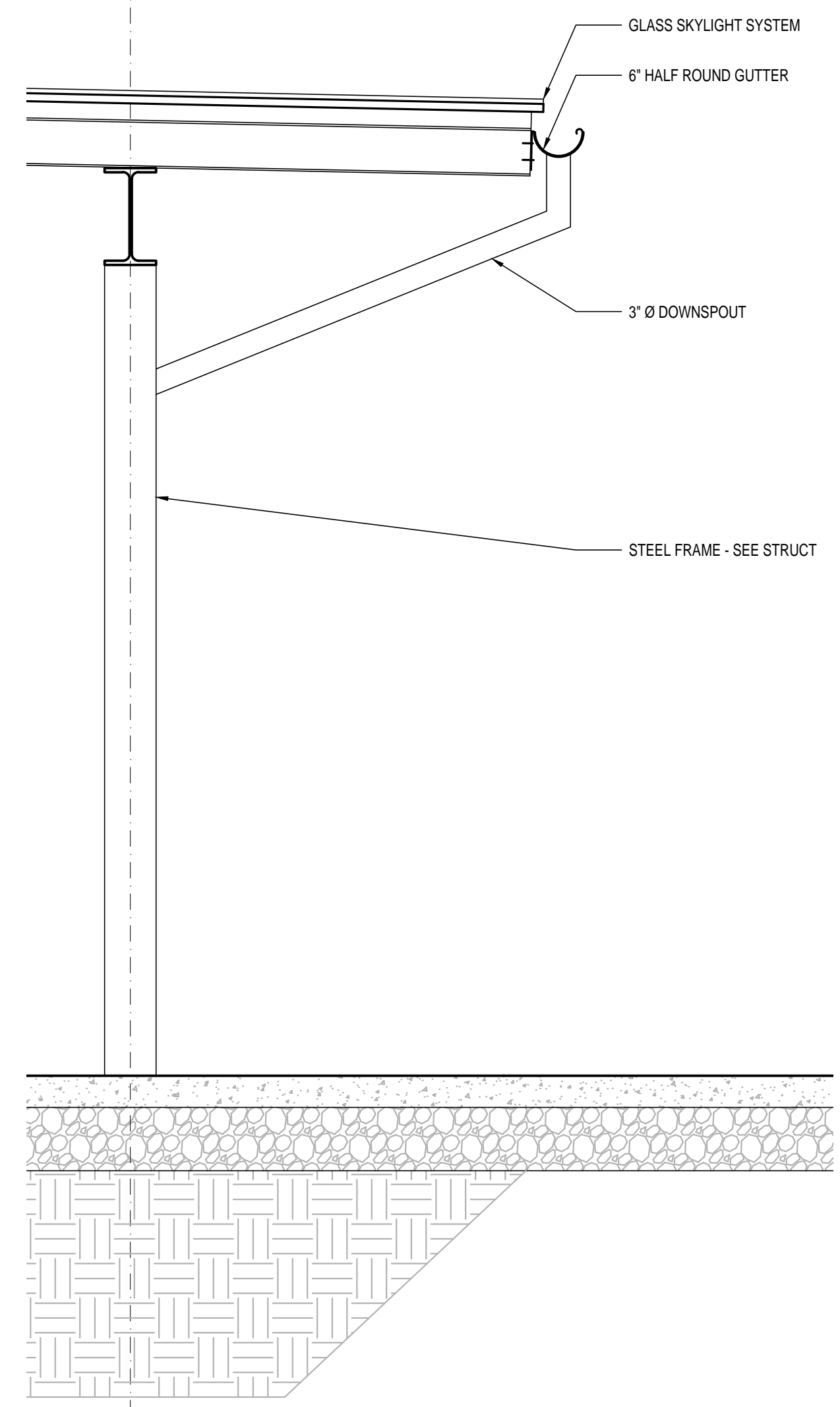

2 WALL SECTION
3/4" = 1'-0"

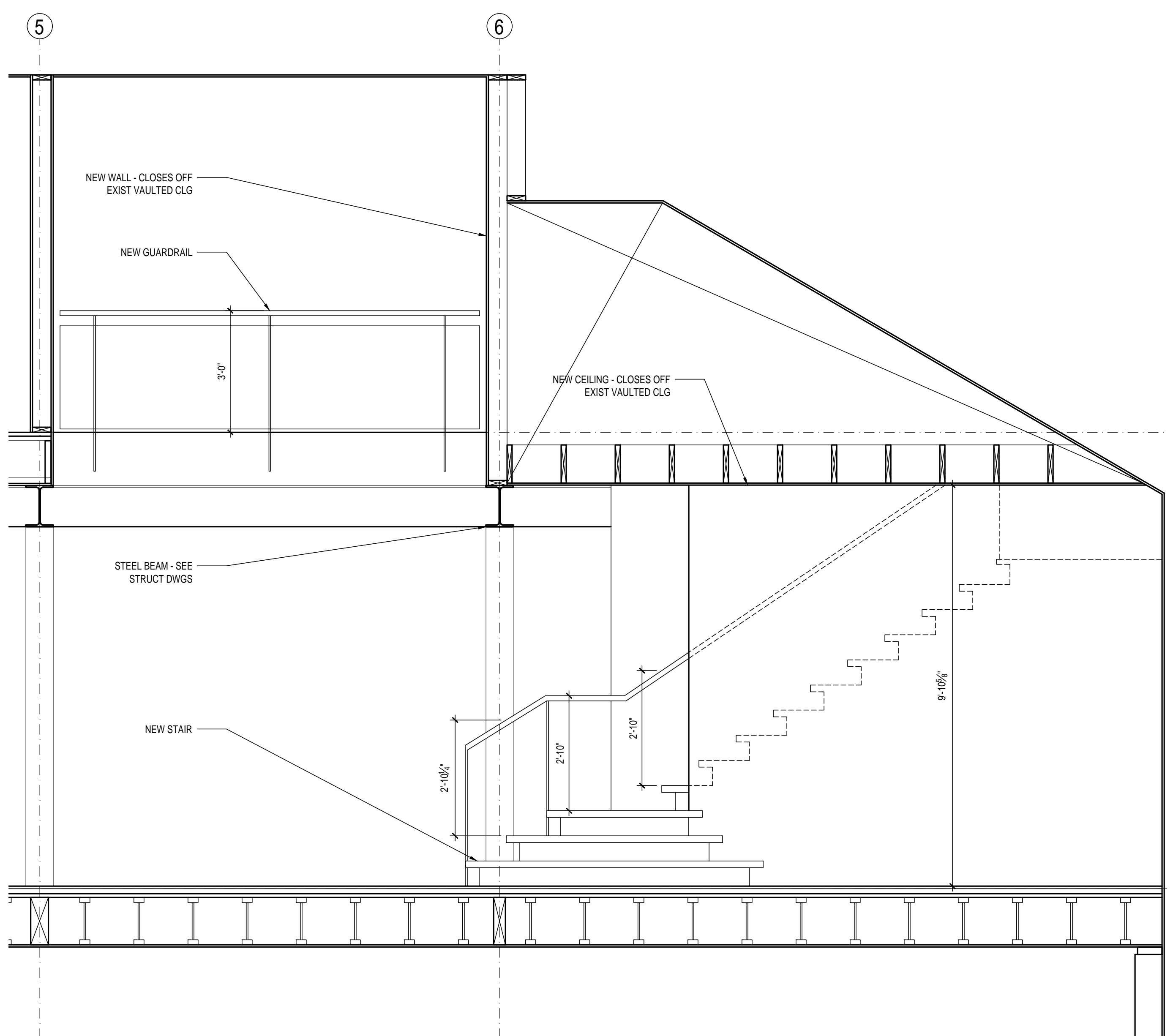

5 BLDG SECTION
1/2" = 1'-0"

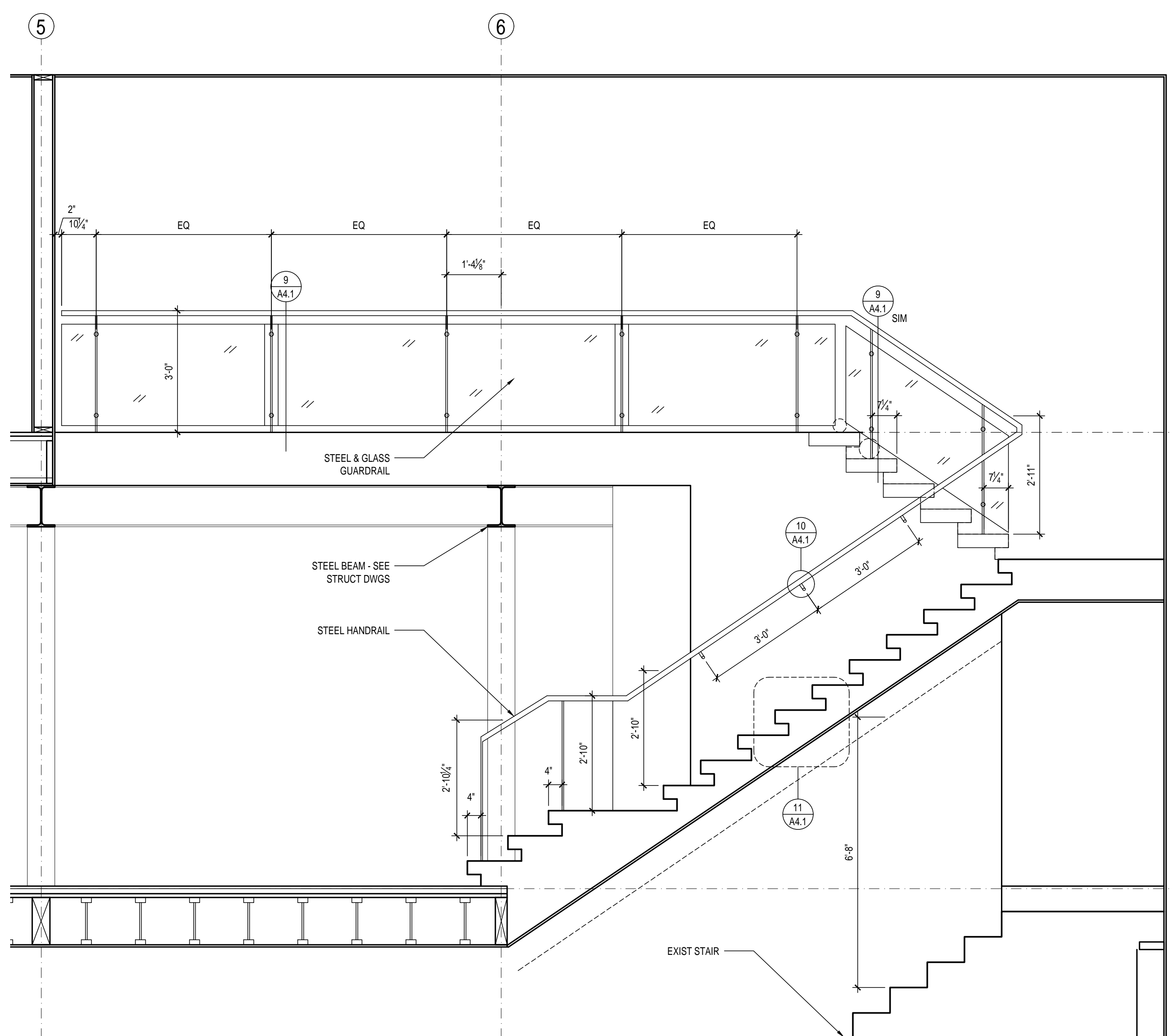

7 STAIR SECTION
1/2" = 1'-0"

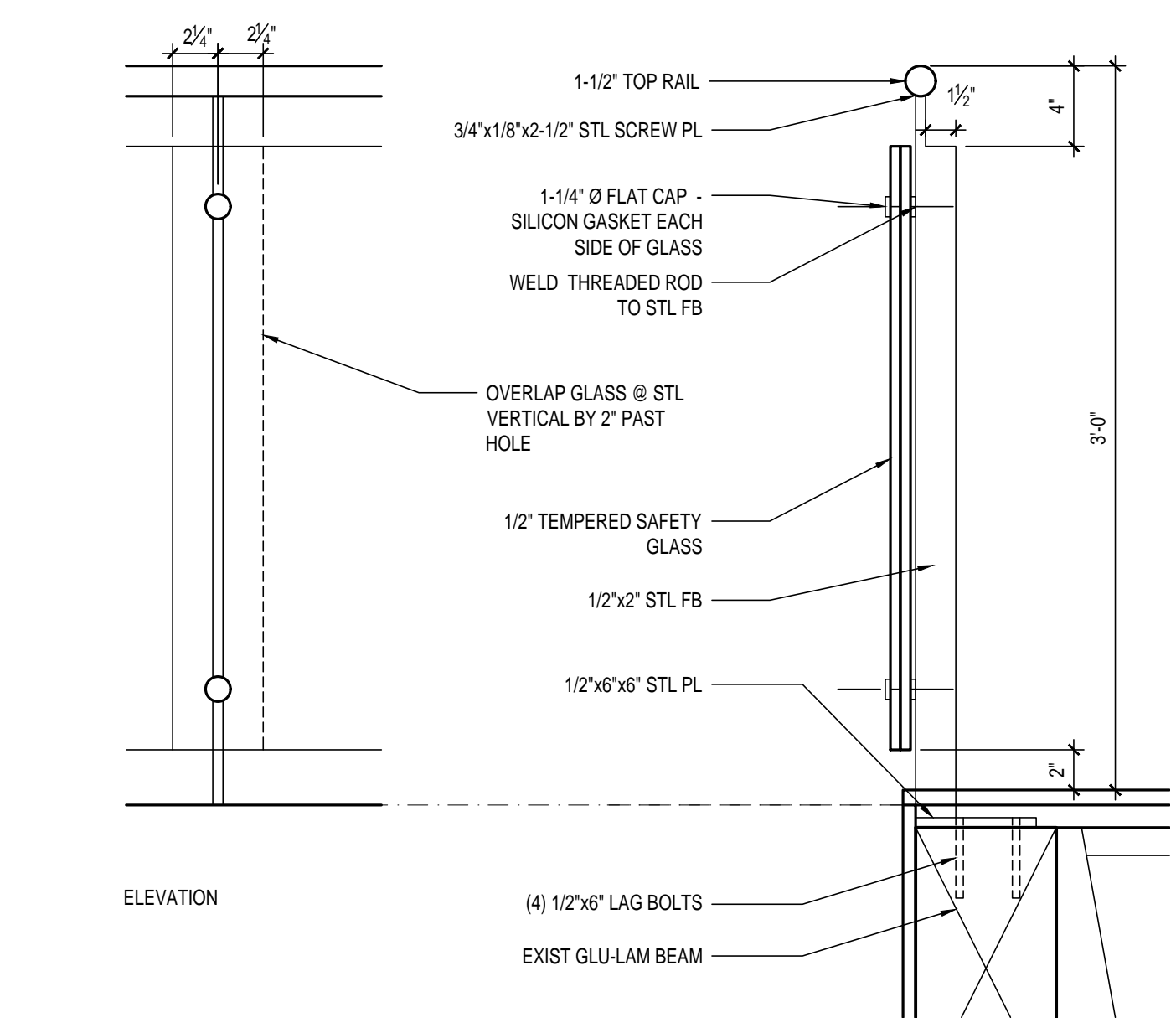

9 GLASS GUARDRAIL
1-1/2" = 1'-0"

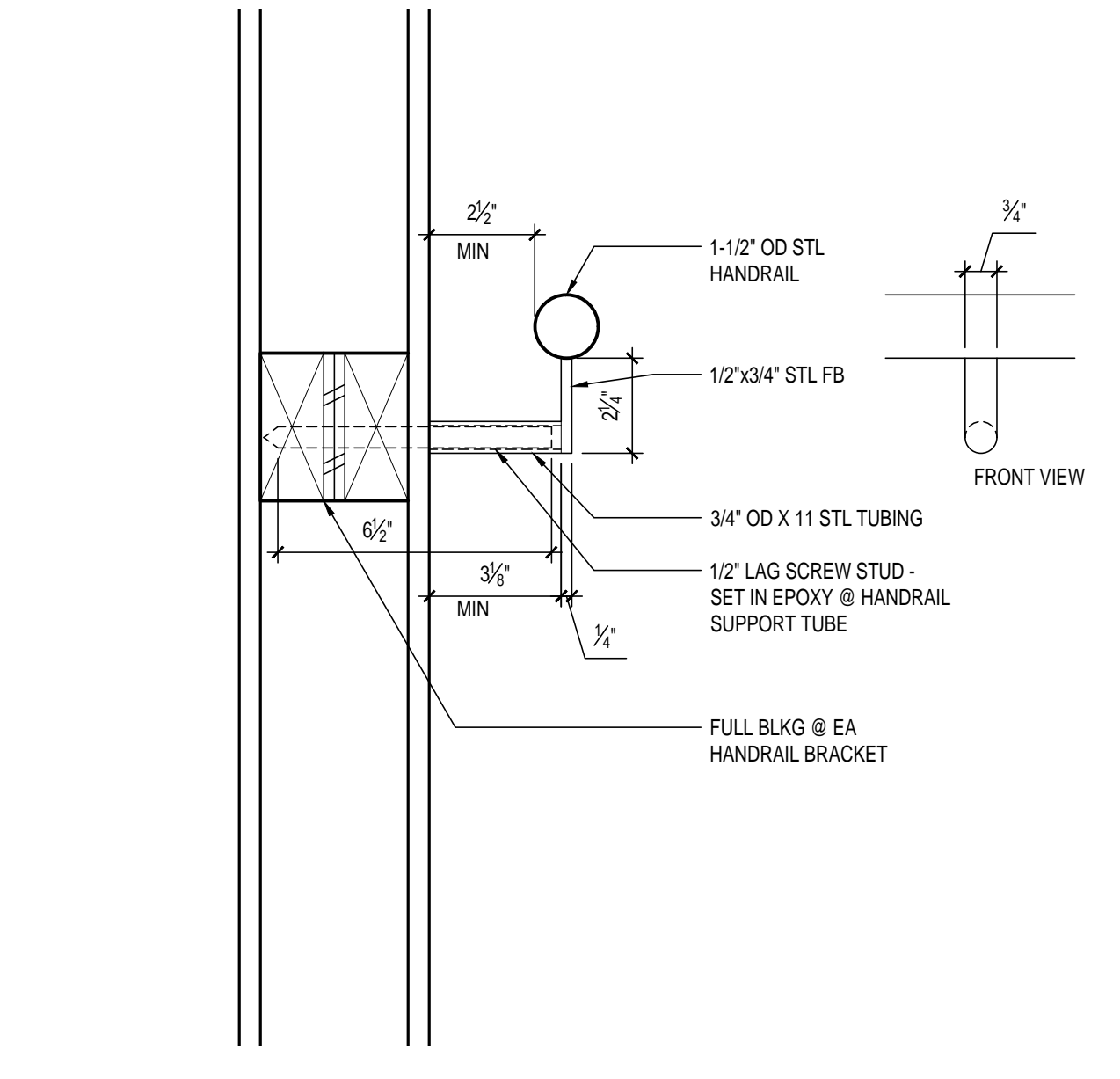

10 HANDRAIL BRACKET
3" = 1'-0"

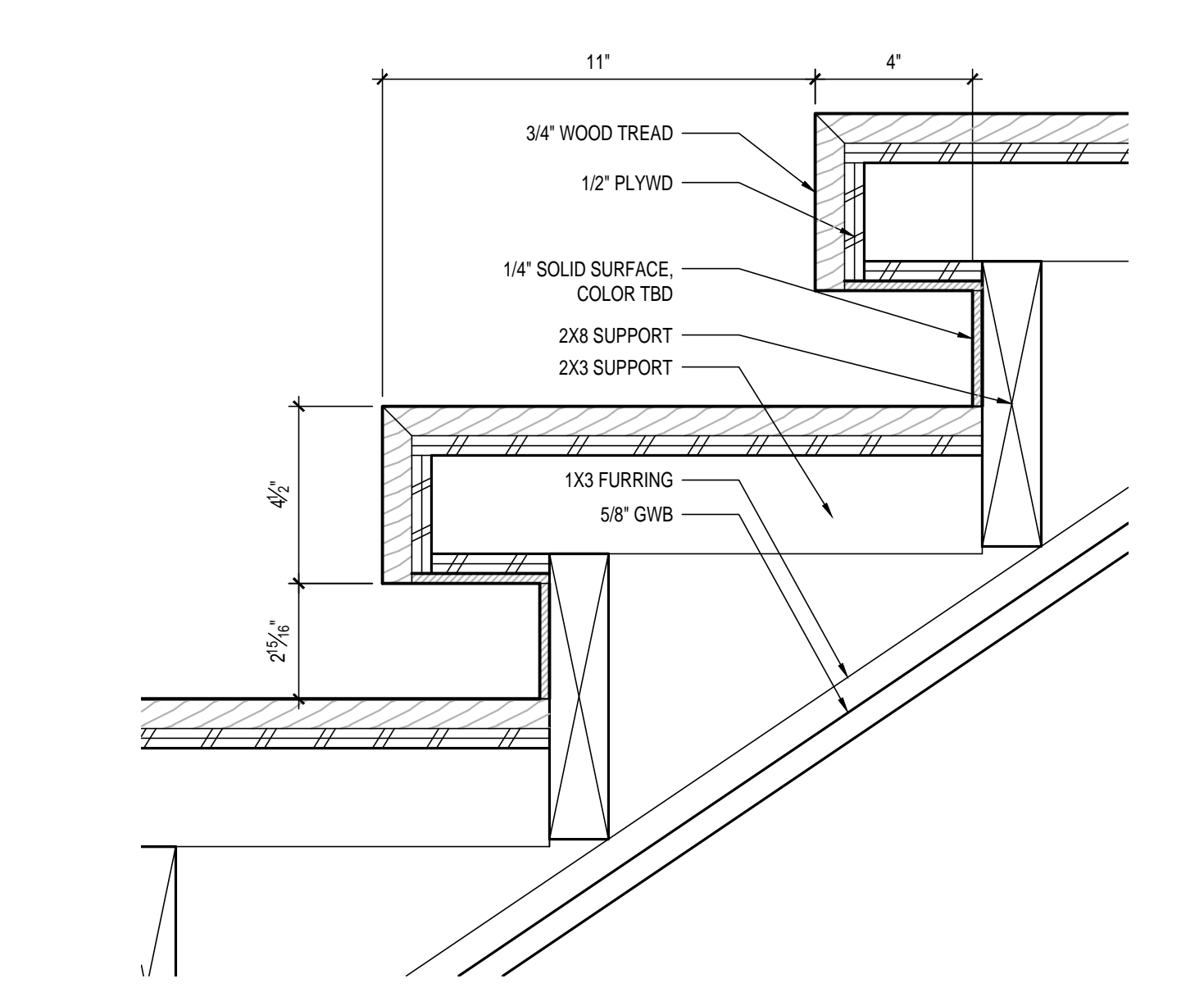

11 STAIR SECTION
3" = 1'-0"

AB - ANCHOR BOLT
ADOL - ADDITIONAL
ALT - ALTERNATE
ALUM - ALUMINUM
ARCH - ARCHITECTURAL
BLDG - BUILDING
BLK (G) - BLOCK(ING)
BM(S) - BEAM(S)
BO xxx - BOTTOM OF xxx
BOT - BOTTOM
BP - BASE PLATE
BPC - BOTTOM PLATE CONNECTION
BTWN - BETWEEN
CIP - CAST IN PLACE
CJT - CONTRACTION/CONSTRUCTION JOINT
CL - CENTERLINE
CLR - CLEAR(ANCE)
CMU - CONCRETE MASONRY UNIT
COL - COLUMN
CONC - CONCRETE
CONN - CONNECTION
CONST - CONSTRUCTION
CONF - CONTINUOUS
CONTR - CONTRACTOR
COORD - COORDINATE
CPR - COMPLETE PENETRATION
CTR - CENTER(ED)
D - DEPTH or DEEP
DBL - DOUBLE
DEG - DEGREE
DEM - DEMOLITION
DET - DETAIL
DIA - DIAMETER
DIAG - DIAGONAL
DIM - DIMENSION
DIST - DISTANCE
DS - DOUBLE STUDS
DWG - DRAWING
EA - EACH
EJ - EACH FACE
EJT - EXPANSION JOINT
EL - ELEVATION
ELEC - ELECTRICAL
EMBED - EMBEDMENT
EN - END NAIL
EOSL - EDGE OF SLAB
EQ - EQUAL
EQUIP - EQUIPMENT
EW - EACH WAY
EXIST - EXISTING
EXP - EXPANSION
EXT - EXTERIOR
FDN - FOUNDATION
FIN - FINISH(ED)
FLG - FLANGE
FLR - FLOOR
FO xxx - FACE OF xxx
FOC - FACE OF CONCRETE
FOF - FACE OF FINISH
FOS - FACE OF STEEL
FS - FAR SIDE
FT - FOOT or FEET
FG - FOOTING
GA - GAGE
GALV - GALVANIZED
GEN - GENERAL
GR - GRADE
GWB - GYPSUM WALLBOARD
HD - HIGH
HDD - HOLD DOWN
HDR - HEADER
HGR - HANGER
HRS - HORIZONTAL
HSS - HOLLOW STRUCTURAL SECTIONS
HT - HEIGHT
HVAC - HEATING, VENTILATING/
AIR CONDITIONING

SPECIAL INSPECTION

1. SPECIAL INSPECTIONS. OBSERVATIONS ARE A SUPPLEMENT TO THE CITY OF KIRKLAND INSPECTIONS REQUIRED BY THE INTERNATIONAL BUILDING CODE (IBC)
SPECIAL INSPECTION BY AAR TESTING AND INSPECTION, INC (JERRY A. ANDERSON, 425-881-5812) SHALL BE RETAINED FOR THE FOLLOWING SPECIAL INSPECTIONS WITH THE EXCEPTION OF THE GEOTECHNICAL WORK WHICH WILL BE INSPECTED BY THE GEOTECH OF RECORD.
SPECIAL INSPECTIONS SHALL NOT BE REQUIRED WHEN THE WORK IS DONE ON THE PREMISES OF A FABRICATOR WITH AN AISC QUALITY CONTROL PROGRAM AND IS APPROVED BY THE BUILDING OFFICIAL TO PERFORM SUCH WORK WITHOUT SPECIAL INSPECTION.
PILE DRIVING
ALL PILE DRIVING SHALL BE CONTINUOUSLY INSPECTED BY A REPRESENTATIVE OF THE GEOTECH OF RECORD.
SOILS
ALL SOILS SHALL BE PERIODICALLY INSPECTED TO VERIFY ASSUMED SOIL VALUES ARE APPLICABLE.
ALL BACKFILLING AND STRUCTURAL FILL OPERATIONS SHALL BE CONTINUOUSLY INSPECTED INCLUDING BACKFILLING BEHIND RETAINING WALLS.
ADHESIVE ANCHORS, EPOXY GROUT
CONTINUOUS INSPECTION OF INSTALLATION OF ALL ADHESIVE ANCHORS AND EPOXY GROUT

STRUCTURAL STEEL

PERFORM QA AND QC INSPECTIONS LISTED IN STRUCTURAL STEEL INSPECTION SCHEDULE BELOW PER AISC 360. IF FABRICATOR HAS AN ACCREDITED QC PROGRAM IN HOUSE THE SHOP FABRICATION INSPECTIONS MAY BE CONDUCTED UNDER THAT PROGRAM. ALL FIELD WELDING SHALL BE INSPECTED BY A SPECIAL INSPECTOR. ALL CJP WELDS SHALL BE ULTRASONICALLY TESTED.
2. THE OWNER, ARCHITECT, STRUCTURAL ENGINEER, AND BUILDING OFFICIAL SHALL BE FURNISHED COPIES OF ALL TEST RESULTS AND REPORTS. REPORTS SHALL INDICATE THAT THE WORK WAS INSPECTED OR WAS NOT IN COMPLIANCE WITH APPROVED CONSTRUCTION DOCUMENTS. DISCREPANCIES SHALL BE BROUGHT TO THE IMMEDIATE ATTENTION OF THE CONTRACTOR FOR CORRECTION. IF THEY ARE NOT CORRECTED, THE DISCREPANCIES SHALL BE BROUGHT TO THE ATTENTION OF THE ENGINEER OF RECORD AND TO THE BUILDING INSPECTOR PRIOR TO THE COMPLETION OF THAT PHASE OF THE WORK. A FINAL REPORT DOCUMENTING REQUIRED SPECIAL INSPECTIONS AND TEST AND CORRECTION OF ANY DISCREPANCIES NOTED IN THE INSPECTIONS OR TESTS, SHALL BE SUBMITTED AT A POINT IN TIME AGREED UPON PRIOR TO THE START OF WORK BY THE OWNER TO THE BUILDING INSPECTOR.
3. IN ADDITION TO THE SUBMITTAL OF REPORTS, THE FOLLOWING MUST BE SUBMITTED TO THE BUILDING INSPECTOR:
CERTIFICATES OF COMPLIANCE FOR THE FABRICATION OF STRUCTURAL, LOAD BEARING OR LATERAL LOAD-RESISTING MEMBERS OR ASSEMBLIES ON THE PREMISES OF A REGISTERED AND APPROVED FABRICATOR.

GENERAL NOTES

- ALL CONSTRUCTION MATERIALS AND WORKMANSHIP SHALL CONFORM TO THE REQUIREMENTS OF THE DRAWINGS, SPECIFICATIONS, AND THE CODES, RULES AND REGULATIONS OF THE 2015 EDITION OF THE INTERNATIONAL BUILDING CODE AS ADOPTED BY THE CITY OF KIRKLAND, WA.
- THE CONTRACTOR SHALL VERIFY ALL DIMENSIONS PRIOR TO CONSTRUCTION. THE ARCHITECT SHALL BE NOTIFIED OF ANY DISCREPANCIES OR INCONSISTENCIES. THIS INCLUDES CONNECTION HARDWARE AND FASTENERS THAT MAY INTERFERE WITH FINISHES OR OTHER ADJACENT SURFACES.
- IF ANY ERRORS OR OMISSIONS APPEAR IN THESE DRAWINGS, SPECIFICATIONS, OR OTHER DOCUMENTS; THE CONTRACTOR SHALL NOTIFY THE STRUCTURAL ENGINEER OR ARCHITECT IN WRITING OF SUCH OMISSION OR ERROR BEFORE PROCEEDING WITH THE WORK.
- NOTES AND DETAILS SHALL TAKE PRECEDENCE OVER GENERAL NOTES AND TYPICAL DETAILS. WHERE NOTES AND DETAILS ON DRAWINGS AND THESE GENERAL NOTES AND TYPICAL DETAILS ARE IN CONFLICT, THE MOST STRINGENT SHALL APPLY. CONDITIONS NOT SPECIFICALLY SHOWN SHALL BE CONSTRUCTED AS SHOWN FOR SIMILAR WORK, SUBJECT TO REVIEW BY THE ARCHITECT AND STRUCTURAL ENGINEER.
- MANUFACTURED MATERIALS SHALL BE APPROVED BY THE ENGINEER OF RECORD PRIOR TO THEIR USE. ALL REQUIREMENTS OF THOSE APPROVALS SHALL BE FOLLOWED.
- ALL STRUCTURAL SYSTEMS THAT ARE TO BE COMPOSED OF MANUFACTURED COMPONENTS TO BE FIELD ERRECTED SHALL BE APPROVED BY THE ENGINEER OF RECORD PRIOR TO THEIR USE AND SHALL BE SUPERVISED BY THE SUPPLIER DURING MANUFACTURING, DELIVERY, HANDLING, STORAGE, AND ERECTION IN ACCORDANCE WITH INSTRUCTIONS PREPARED BY THE SUPPLIER.
- FRAMING MEMBERS WHICH ARE NOT DIMENSIONED SHALL BE EQUALLY SPACED BETWEEN DIMENSIONED POINT OR MEMBERS.
- SEE ARCHITECTURAL DRAWINGS FOR THE FOLLOWING:
A. SIZE AND LOCATION OF ALL DOOR AND WINDOW OPENINGS AND THRESHOLD REQUIREMENTS.
B. SIZE AND LOCATION OF ALL NON-BEARING PARTITIONS.
C. SIZE AND LOCATION OF ROOF, FLOOR AND WALL OPENINGS.
D. SIZE AND LOCATION OF DEPRESSED AREAS, CHANGES IN ELEVATION, FLOOR AND ROOF DRAINS, SLOPES, CONCRETE CURBS, LEDGES, PADS AND ISLANDS, CHAMFERS, GROOVES, INSERTS, ETC.
E. DIMENSIONS NOT SHOWN ON THE STRUCTURAL DRAWINGS.
F. EXTERIOR WALL SYSTEMS.
- SEE ARCH, MECHANICAL, PLUMBING AND ELECTRICAL DRAWINGS FOR THE FOLLOWING:
A. PIPE RUNS, SLEEVES, HANGERS, TRENCHES, WALL, ROOF AND FLOOR OPENINGS, ETC., NOT SHOWN OR NOTED.
B. ELECTRICAL CONDUIT RUNS, BOXES, OUTLETS IN WALLS AND SLABS.
C. ANCHORAGE AND BRACING FOR ELECTRICAL, MECHANICAL OR PLUMBING EQUIPMENT TO THE STRUCTURE.
D. ANCHOR BOLTS FOR MOTOR MOUNTS.
E. SIZE, WEIGHT AND LOCATION OF MACHINES AND EQUIPMENT BASES.
- THE CONTRACT DOCUMENTS REPRESENT THE FINISHED STRUCTURE. THEY DO NOT INDICATE THE METHOD OF CONSTRUCTION. THE CONTRACTOR SHALL PROVIDE ALL MEASURES NECESSARY TO PROTECT THE STRUCTURE DURING CONSTRUCTION. SUCH MEASURES SHALL INCLUDE, BUT NOT BE LIMITED TO, BRACING, SHORING FOR LOADS DUE TO CONSTRUCTION EQUIPMENT, ETC. OBSERVATION VISITS TO THE SITE BY THE STRUCTURAL ENGINEER SHALL NOT INCLUDE INSPECTION OF THE ABOVE ITEMS.
- OPENINGS, POCKETS, ETC. SHALL NOT BE PLACED IN STRUCTURAL MEMBERS UNLESS SPECIFICALLY DETAILED ON THE STRUCTURAL DRAWINGS. NOTIFY THE STRUCTURAL ENGINEER WHEN DRAWINGS BY OTHERS SHOW OPENINGS, POCKETS, ETC., LARGER THAN 6 INCHES NOT SHOWN ON THE STRUCTURAL DRAWINGS, BUT WHICH ARE LOCATED IN STRUCTURAL MEMBERS.
- SPECIFICATIONS, CODES, AND STANDARDS NOTED IN THE CONTRACT DOCUMENTS SHALL BE OF THE LATEST APPROVED ISSUE, INCLUDING SUPPLEMENTS, UNLESS OTHERWISE NOTED. MATERIAL SPECIFICATIONS ARE ASTM LATEST EDITION.
- CONTRACTOR SHALL PROVIDE TEMPORARY BRACING FOR THE STRUCTURE AND STRUCTURAL COMPONENTS UNTIL ALL FINAL CONNECTIONS HAVE BEEN COMPLETED IN ACCORDANCE WITH THE PLANS.

DESIGN CRITERIA

DESIGN LOADS: ROOF DEAD LOAD ROOF SNOW LOAD	PER CALCULATIONS 25 PSF
WIND DESIGN: BASIC WIND SPEED (3 SECOND GUST) EXPOSURE CATEGORY IMPORTANCE FACTOR Iw Kzt SEISMIC DESIGN: SEISMIC USE GROUP Sds Sd1 SOIL CLASSIFICATION IMPORTANCE FACTOR Ie R	110 MPH D 1.0 1.0 1.0 I 0.928 0.485 D (ASSUMED) 1.0 3.5 & 6.5

SEISMIC DESIGN FORCE SYSTEM CONSISTS OF ORDINARY STEEL MOMENT FRAMES AND LIGHT FRAMED PLYWOOD SHEAR WALLS.

SOILS
SHORING INSTALLATION AND DESIGN BASED UPON GEOTECHNICAL REPORT PREPARED BY ROBERT M. PRIDE, INC CONSULTING ENGINEER DATED 8/20/2005.

SOILS CRITERIA	
ALLOWABLE BEARING	3000 PSF
PIPE PILES	
2"ø	6000 LBS

STRUCTURAL STEEL INSPECTION SCHEDULE	
INSPECTION TASKS PRIOR TO WELDING	
1. REVIEW MANUFACTURERS SPECIFICATIONS FOR WELDING CONSUMABLES.	P
2. MATERIAL IDENTIFICATION	P
3. WELDER IDENTIFICATION SYSTEM	O
4. FIT UP OF FILLET WELDS (DIMENSIONS, CLEANLINESS, TACKING)	O
5. CHECK WELDING EQUIPMENT	O
INSPECTION TASKS DURING WELDING	
1. REVIEW WELDERS QUALIFICATIONS	O
2. CONTROL AND HANDLING OF WELDING CONSUMABLES (PACKAGING, EXP CONTROL)	O
3. ENVIRONMENTAL CONDITIONS (WIND SPEED WITHIN LIMITS, PRECIP AND TEMP)	O
4. WELDING PROCEDURES FOLLOWED (WELDING EQUIPMENT SETTINGS, TRAVEL SPEED, WELDING MATERIALS, SHIELD GAS TYPE AND FLOW RATE, PREHEAT, INTERPASS TEMP MAINTAINED, PROPER POSITION)	O
5. WELDING TECHNIQUES (INTERPASS AND FINAL CLEANING, EACH PASS MEETS PROFILE LIMITS, EA PASS MEETS QUALITY REQUIREMENTS)	O
INSPECTION TASKS AFTER WELDING	
1. WELDS CLEANED	O
2. SIZE LENGTH AND LOCATION OF WELDS	P
3. WELDS MEET VISUAL ACCEPTANCE CRITERIA (CRACK PROHIBITION, WELD BASE METAL FUSION, CRACKER CROSS SECTION, WELD PROFILES, WELD SIZE, UNDERCUT, POROSITY)	P
4. K-AREA	P
5. ARC STRIKES	P
6. REPAIR ACTIVITIES	P
7. DOCUMENT ACCEPTANCE OR REJECTION OF MEMBER OR WELDED JOINT	P
O = OBSERVE ON A RANDOM BASIS P = PERFORM TASK FOR EA WELDED JT OR MEMBER	

FOUNDATIONS

- ALL FOUNDATIONS SHALL BE FOUNDED A MINIMUM OF 18" BELOW LOWEST ADJACENT FINAL FINISH FLOOR OR GRADE.
- ALL BEARING SURFACES SHALL BE INSPECTED BY GEOTECH OF RECORD PRIOR TO PLACING CONCRETE.
- ALL PIPE PILE INSTALLATION SHALL BE CONTINUALLY INSPECTED BY A REPRESENTATIVE OF THE GEOTECH OF RECORD.
- CONTRACTOR SHALL DEVELOP PILE LOCATION PLAN COMPLETE WITH SURVEYING COORDINATES AND DIMENSIONS LOCATING PILES RELATIVE TO BUILDING CORNERS. SUBMIT TO ARCH FOR REVIEW PRIOR TO INSTALLATION OF PILES.

CONCRETE

- ALL CONCRETE CONSTRUCTION SHALL CONFORM TO THE "BUILDING CODE REQUIREMENTS FOR REINFORCED CONCRETE" ACI 318 AND ACI 301, WITH MODIFICATIONS AS NOTED IN THE CONTRACT DOCUMENTS.
- PORTLAND CEMENT SHALL CONFORM TO ASTM C-150 TYPE I OR TYPE II.
- COARSE AND FINE AGGREGATE FOR NORMAL WEIGHT CONCRETE SHALL CONFORM TO ASTM C-33.
- AGGREGATE FOR LIGHTWEIGHT CONCRETE SHALL CONFORM TO ASTM C-330 AND THE PROJECT SPECIFICATIONS.
- WATER SHALL BE CLEAR AND SHALL CONFORM TO ASTM C-94.
- CONCRETE MIXING OPERATION SHALL CONFORM TO ASTM C-94.
- ADD TO ALL CONCRETE EXPOSED TO WEATHER MICROAIR OR MBVR AIR ENTRAINING AGENT TO ATTAIN 5 PERCENT +/- 1 PERCENT ENTRAINED AIR, BY VOLUME, CONFORMING TO ASTM C-260. ALL REFERENCE DATA USED FOR PAST PERFORMANCE DESIGN SHALL HAVE CONTAINED THE SAME ADMIXTURE BRAND AS THAT USED IN THE MIX SUBMITTED.
- CONCRETE STRENGTHS SHALL BE VERIFIED BY 28-DAY CYLINDER TESTS, UNLESS OTHERWISE APPROVED. CONCRETE SHALL BE AS FOLLOWS:

ELEMENT	DES STRENGTH USED IN CALCS	MIX DESIGN STRENGTH PSI	CONCRETE TYPE
FOOTINGS	2500	4000	5 1/2 SACK W/C<.45
WALLS	2500	4000	5 1/2 SACK W/C<.45
SLAB ON GRADE	2500	4000	5 1/2 SACK W/C<.45

- CONTRACTOR MAY USE AN ADMIXTURE SYSTEM TO PRODUCE FLOWABLE CONCRETE. MAXIMUM SLUMP SHALL NOT EXCEED 10 INCHES MEASURED AT THE PUMP. THE WATER/CEMENTIOUS MATERIAL RATIO OF THE APPROVED MIXES SHALL BE MAINTAINED OR LOWERED WHEN FLOWABLE CONCRETE IS USED. A REPRESENTATIVE OF THE ADMIXTURE SYSTEM SHALL ASSIST IN DETERMINING PROPORTIONS FOR FLOWABLE CONCRETE AND SHALL BE REVIEWED BY THE STRUCTURAL ENGINEER AND ARCHITECT PRIOR TO EMPLOYING THIS PROCEDURE.
- THE FOLLOWING MINIMUM CONCRETE COVER SHALL BE PROVIDED FOR REINFORCEMENT PLACED IN CAST-IN-PLACE CONCRETE:

A. CONCRETE CAST AGAINST AND PERMANENTLY EXPOSED TO EARTH:	3"
B. CONCRETE EXPOSED TO EARTH OR WEATHER: #6 THROUGH #18 BARS #5 BAR, W31 OR D31 WIRE, AND SMALLER	2" 1 1/2"
C. CONCRETE NOT EXPOSED TO WEATHER OR IN CONTACT WITH GROUND: SLABS, WALLS, JOISTS: #14 AND #18 BARS #11 BARS AND SMALLER BEAMS, COLUMNS: PRIMARY REINFORCEMENT, TIES, STIRRUPS, SPIRALS SHELLS, FOLDED PLATE MEMBERS: #6 BAR AND LARGER #5 BAR, W31 OR D31 WIRE, AND SMALLER	1 1/2" 3/4" 1 1/2" 3/4" 1/2"

- BASE PLATE GROUT SHALL BE NON-SHRINK TYPE WITH F'c=7000 PSI, GRADE B, CONFORMING TO ASTM C-1107.
- PLACEMENT OF CONCRETE SHALL CONFORM TO ACI 304 AND THE CONTRACT DOCUMENTS. SLABLAST ALL CONCRETE SURFACES AGAINST WHICH CONCRETE IS TO BE PLACED.
- PROJECTING CORNERS OF BEAMS, WALLS, COLUMNS, ETC., SHALL BE FORMED WITH A 3/4 INCH CHAMFER, UNLESS OTHERWISE NOTED ON THE ARCHITECTURAL DRAWINGS.
- ALL REINFORCING BARS, ANCHOR BOLTS AND OTHER CONCRETE INSERTS SHALL BE WELL SECURED IN POSITION PRIOR TO PLACING CONCRETE.
- PROVIDE SLEEVES FOR PLUMBING AND ELECTRICAL OPENINGS IN CONCRETE BEFORE PLACING. REINFORCING SHALL NOT BE CUT. CORING OF CONCRETE IS NOT PERMITTED EXCEPT AS INDICATED.
- CONDUIT OR PIPE SIZE (O.D.) SHALL NOT EXCEED ONE THIRD OF THE SLAB THICKNESS AND SHALL BE PLACED BETWEEN THE TOP AND BOTTOM REINFORCING, UNLESS SPECIFICALLY DETAILED OTHERWISE. CONCENTRATIONS OF CONDUIT OR PIPES SHALL BE AVOIDED EXCEPT WHERE DETAILED OPENINGS ARE PROVIDED.
- CURING COMPOUNDS USED ON CONCRETE TO RECEIVE A FINISH SHALL BE APPROVED BY THE FINISH APPLICATOR BEFORE USE.

REINFORCING STEEL

- REINFORCING STEEL SHALL BE DETAILED, INCLUDING HOOKS AND BENDS, AND PLACED IN ACCORDANCE WITH ACI 315 AND ACI 318.
- REINFORCING STEEL SHALL CONFORM TO ASTM A-615 OR A-706, GRADE 60.
- WELDED WIRE FABRIC SHALL CONFORM TO ASTM A-185.
- ALL REINFORCING BAR BENDS SHALL BE MADE COLD.
- REINFORCING SPLICES SHALL BE MADE AS INDICATED ON THE DRAWINGS.
- DOWELS BETWEEN FOOTINGS AND WALLS OR COLUMNS SHALL BE THE SAME GRADE, SIZE AND SPACING AS THE VERTICAL REINFORCING, RESPECTIVELY, UNLESS OTHERWISE NOTED.
- PROVIDE #4 x 2'-0" DIAGONAL BAR AT ALL REENTRANT CORNERS OF CONCRETE SLABS ON GRADE.
- NO BARS PARTIALLY EMBEDDED IN HARDENED CONCRETE SHALL BE FIELD BENT UNLESS SPECIFICALLY SO DETAILED AND REVIEWED BY THE STRUCTURAL ENGINEER.
- WELDING OF REINFORCEMENT SHALL BE WITH LOW HYDROGEN ELECTRODES IN CONFORMANCE WITH ACI 318-83 AND THE RECOMMENDATIONS OF THE AMERICAN WELDING SOCIETY, AWS D1.4 AND WITH THE REVIEW OF THE STRUCTURAL ENGINEER.
- PROVIDE SHOP DRAWINGS FOR REINFORCING FOR CONCRETE BEAMS AND GRADE BEAMS.

ANCHORAGE

- EXPANSION SHALL BE ZINC PLATED IN ACCORDANCE WITH ASTM B633, AND CONFORM WITH FS FF-S-325, GROUP II, TYPE 4, CLASS 1.
- SLEEVE ANCHORS SHALL BE ZINC PLATED IN ACCORDANCE WITH ASTM B633, AND CONFORM WITH FS FF-S-325, GROUP II, TYPE 3, CLASS 3.
- FLUSH SHELL ANCHORS SHALL BE ZINC PLATED IN ACCORDANCE WITH ASTM B633, AND CONFORM WITH FS FF-S-325, GROUP II, TYPE 3, CLASS 3.
- ADHESIVE ANCHORS SHALL CONSIST OF ALL-THREAD ANCHOR ROD, NUT, WASHER, AND EPOXY INJECTION GEL OR ADHESIVE CAPSULE SYSTEM. ANCHOR RODS SHALL BE MANUFACTURED FROM A-36 MATERIAL, ZINC PLATED IN ACCORDANCE WITH ASTM B633.
- ALL RELATED PRODUCTS, MATERIALS, AND INSTALLATION SHALL BE IN ACCORDANCE WITH THE MANUFACTURER'S RECOMMENDATIONS.
- NOTATIONS ON DRAWINGS RELATING TO EXPANSION, SLEEVE, FLUSH, OR ADHESIVE ANCHORS AND OTHER CONNECTING DEVICES REFER TO CONNECTORS MANUFACTURED BY POWERS FASTENING, INC. EQUIVALENT DEVICES BY OTHER MANUFACTURERS MAY BE SUBSTITUTED PROVIDED THAT THEY HAVE ICBO APPROVAL FOR EQUAL OR GREATER LOAD CAPACITIES AND ARE REVIEWED BY THE STRUCTURAL ENGINEER.

STRUCTURAL STEEL, MISC. METAL

- STRUCTURAL STEEL DETAILING, FABRICATION AND ERECTION SHALL BE BASED ON THE LATEST EDITION AND SUPPLEMENTS OF THE AISC "SPECIFICATION FOR STRUCTURAL STEEL FOR BUILDINGS - ALLOWABLE STRESS DESIGN AND PLASTIC DESIGN". STRUCTURAL STEEL SHALL CONFORM TO THE FOLLOWING REQUIREMENTS.
TYPE OF MEMBER
ASTM SPECIFICATION
Fy
PLATES, SHAPES, ANGLES, AND W SHAPES
A36 (UON)
36 KSI
HOLLOW STRUCTURAL SECTIONS (ROUND, SQUARE OR RECTANGLE)
A500 (GRADE B)
46 KSI
ANCHOR RODS (EMBEDDED IN CONCRETE)
A307 (UON)
CONNECTION BOLTS (STEEL TO STEEL)
A325 (UON)
CONNECTION BOLTS (STEEL TO WOOD)
A307 (UON)
2. WELDED HEADED STUDS SHALL BE NELSON GRANULAR FLUX-FILLED STUDS OR AN APPROVED EQUAL.
3. THE STRUCTURAL STEEL FABRICATOR SHALL FURNISH SHOP DRAWINGS FOR REVIEW BEFORE FABRICATION.
4. ALL WELDS SHALL BE PREQUALIFIED IN CONFORMANCE WITH AISC AND AWS STANDARDS AND SHALL BE PERFORMED BY WELDERS WABO CERTIFIED. USE E70XX ELECTRODES.
5. WELD LENGTHS CALLED FOR ON THE PLANS ARE THE NET EFFECTIVE LENGTH REQUIRED. WELD SIZE SHALL BE AISC MINIMUM, UNLESS OTHERWISE NOTED.

WOOD

- FRAMING LUMBER SHALL BE GRADED AND MARKED IN CONFORMANCE WITH WCLB STANDARD GRADING AND DRESSING RULES FOR WEST COAST LUMBER NO. 16, LATEST EDITION. UNLESS OTHERWISE NOTED ON THE DRAWINGS, LUMBER GRADES SHALL BE AS FOLLOWS:
A. JOISTS: 2 INCH AND 3 INCH THICKNESS, HEM FIR NO. 1.
B. BEAMS AND STRINGERS: DOUGLAS FIR NO. 2.
C. POST AND TIMBERS: DOUGLAS FIR NO. 12
D. PLATES AND MISCELLANEOUS LIGHT FRAMING: HEM FIR STANDARD.
E. STUDS: HEM FIR STUD.
2. MINIMUM NAILING REQUIREMENTS:
UNLESS OTHERWISE NOTED, MINIMUM NAILING SHALL CONFORM TO IBC-TABLE 2304.9.1 AND AS FOLLOWS:
A. JOISTS OR RAFTERS TO SIDES OF STUDS 8 INCH OR LESS
3-16D
B. FOR EACH ADDITIONAL 4 INCH IN DEPTH OF JOISTS
1-16D
C. JOISTS OR RAFTERS AT ALL BEARINGS-TOENAILS EACH SIDE
2-10D
D. STUDS TO BEARING - TOENAILS EACH SIDE
2-10D
E. BLOCKING BETWEEN JOISTS OR RAFTERS:
TO JOIST OR RAFTERS-TOENAILS EACH SIDE EACH END
2-10D
TO JOIST OR RAFTER BEARINGS-TOENAILS EACH SIDE
2-10D
F. CROSS-BRIDGING BETWEEN JOISTS OR RAFTERS TOENAILS EACH END
2-8D
G. BLOCKING BETWEEN STUDS - TOENAILS EACH END
2-10D
H. DOUBLE TOP PLATES - LOWER PLATE TO TOP OF STUD
2-16D
J. UPPER TO LOWER PLATE - STAGGERED
16D @ 16" OC
K. WALL TOP PLATE SPLICE -
8-16d
L. MULTIPLE JOISTS - STAGGERED
16D @ 12" OC
M. MULTIPLE JOISTS - STAGGER FOR WIDTHS
16D @ 12" OC
MORE THAN 4 INCHES

INDIVIDUAL MEMBERS OF BUILT-UP POSTS AND BEAMS SHALL EACH BE ATTACHED WITH 16D SPIKES AT 12" OC STAGGERED, MIN.

- ALL NAILS SHALL BE COMMON WIRE NAILS. WHENEVER POSSIBLE, NAILS DRIVEN PERPENDICULAR TO THE GRAIN SHALL BE USED. THERE SHALL BE A MINIMUM OF 2 NAILS AT ALL WOOD CONTACTS AND JOINTS USING BD NAILS FOR 1 INCH THICK MATERIAL, 16D NAILS FOR 2 INCH THICK MATERIAL, AND 40D NAILS FOR 3 INCH THICK MATERIAL. ALL CONTINUOUS CONTACTS PROVIDE MINIMUM NAILS AT 12" OC WITH NAIL SIZES AS CALLED ABOVE.
- NOTATIONS ON DRAWINGS RELATING TO FRAMING CULPS, JOIST HANGERS, AND OTHER CONNECTING DEVICES REFER TO CATALOG NUMBERS OF STRONG-TIE CONNECTORS MANUFACTURED BY THE SIMPSON COMPANY. EQUIVALENT DEVICES BY OTHER MANUFACTURERS MAY BE SUBSTITUTED PROVIDED THAT THEY HAVE ICBO APPROVAL FOR EQUAL OR GREATER LOAD CAPACITIES AND ARE REVIEWED BY THE STRUCTURAL ENGINEER.
- AT SAWN TIMBER JOISTS WITH THICKNESS-TO-DEPTH RATION OF 1:6 AND GREATER, PROVIDE CROSS-BRIDGING AT 8'-0" OC AND SOLID BLOCKING AT BEARING POINTS.
- ALL BEARING AND EXTERIOR STUD WALLS SHALL BE 2x6 @ 16" OC UNLESS OTHERWISE NOTED.
- PROVIDE CONTINUOUS SOLID BLOCKING AT MID-HEIGHTS AND AT INTERVALS NOT TO EXCEED 8'-0" OF ALL STUD-BEARING WALLS OVER 8'-0" IN HEIGHT.
- ALL CANTS AND CRICKETS SHALL BE PLACED OVER BASIC ROOF SHEATHING. SEE ARCHITECTURAL DRAWINGS FOR DETAILS AND LOCATIONS.
- ALL WOOD STUD WALL SILL PLATES SHALL BE ATTACHED TO CONCRETE OR MASONRY WITH 5/8 INCH DIAMETER ANCHOR BOLTS AT 48" OC, UNLESS OTHERWISE NOTED.
- ALL WOOD STUD WALLS SHALL HAVE LOWER WOOD PLATE ATTACHED TO WOOD FRAMING BELOW WITH 16D NAILS AT 6" OC STAGGERED UNLESS SHOWN OTHERWISE.
- FASTEN ALL POSTS TO CONCRETE WITH "CB" COLUMN BASE OR EQUAL.
- ALL WOOD PLATES AND BLOCKING IN DIRECT CONTACT WITH CONCRETE OR MASONRY SHALL BE PRESSURE TREATED WITH AN APPROVED PRESERVATIVE IN ACCORDANCE WITH AWPS-FDN, AND BEAR THAT QUALITY MARK.
- PROVIDE 3x3x.229" PLATE WASHERS UNDER ALL ANCHOR BOLT NUTS IN CONTACT WITH WOOD.
- ATTACH TIMBER JOISTS TO FLUSH HEADERS AND BEAMS WITH "U" SERIES METAL JOIST HANGERS TO SUIT THE JOIST SIZE.
- ALL PLYWOOD SHALL BE DOUGLAS FIR, STRUCTURAL II AND SHALL CONFORM TO APA C-D INTERIOR GRADE WITH EXTERIOR GLUE AND WITH PRODUCT STANDARD PS1. WOOD-BASED STRUCTURAL-USE PANELS SHALL CONFORM WITH PRODUCT STANDARD PS2.
- PANEL TYPE AND NAILING, USE UNLESS OTHERWISE NOTED:

FLOOR:	1½" T&G APA RATED PANELS 10d @ 4" OC AT ALL SUPPORTED EDGES. 10d @ 12" OC AT INTERMEDIATE BEARING POINTS.
ROOF:	¾" PW APA RATED PANELS 10d @ 4" OC AT SUPPORTED SHEET EDGES. 10d @ 12" OC AT INTERMEDIATE BEARING POINTS.
WALLS:	1½" APA RATED PANELS 10d @ 6" OC AT SHEET EDGES UNLESS NOTED OTHERWISE ON SHEAR WALL SCHEDULE. 10d @ 12" OC AT INTERMEDIATE BEARING POINTS.
PLYWOOD AND WOOD-BASED STRUCTURAL-USE PANELS USED FOR WALL SHEATHING SHALL HAVE SOLID BLOCKING AT ALL EDGES.	

- MACHINE APPLIED NAILING IS SUBJECT TO A SATISFACTORY DEMONSTRATION AND THE APPROVAL OF THE CHECKING AGENCY AND THE ARCHITECT. NAIL HEADS SHALL NOT PENETRATE THE OUTER PLY MORE THAN WOULD BE NORMAL FOR A HAND HAMMER. EDGE DISTANCES SHALL BE MAINTAINED. SHINERS SHALL BE REMOVED AND REPLACED. THE APPROVAL IS SUBJECT TO CONTINUED SATISFACTORY PERFORMANCE. MACHINE APPLIED NAILING ONLY ON PLYWOOD GREATER THAN 5/16".
- ALL FASTENERS, INCLUDING NUTS AND WASHERS, IN CONTACT WITH PRESERVATIVE TREATED LUMBER OR EXPOSED TO WEATHER SHALL BE HOT DIPPED GALVANIZED OR STAINLESS STEEL.
- CONNECTORS THAT ARE USED IN EXTERIOR APPLICATIONS AND IN CONTACT WITH PRESERVATIVE TREATED WOOD SHALL HAVE COATING TYPES AND WEIGHTS IN ACCORDANCE WITH THE TREATED WOOD OR CONNECTOR MANUFACTURER'S RECOMMENDATIONS. IN THE ABSENCE OF SUCH RECOMMENDATIONS, A MINIMUM OF ASTM A653, TYPE G185 ZINC COATING GALVANIZED STEEL OR EQUIVALENT SHALL BE USED.

GARY GILL, SE
1125 NE 152nd STREET
SHORELINE, WA 98155
PH: 206-992-2728
GILL26608@YAHOO.COM

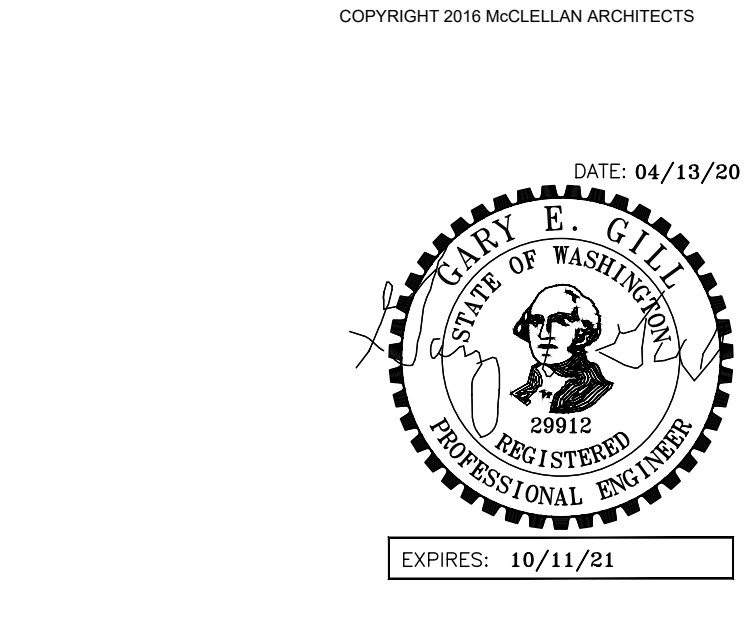

PROJECT:
AGNIESZKA & STEVE LOUDEN
3315 97TH AVE SE
MERCER ISLAND, WA

CLIENT:
LOUDEN RESIDENCE
3315 97TH AVE SE
MERCER ISLAND, WA

ISSUE:
PERMIT SET
04/13/2020

DATE:
13 APRIL 2020

SHEET TITLE:
GENERAL NOTES &

ABBREVIATIONS

SHEET:
S1.0

GARY GILL, SE
1125 NE 152nd STREET
SHORELINE, WA 98155
PH: 206-992-2728
GILL26608@YAHOO.COM

COPYRIGHT 2016 MCLELLAN ARCHITECTS

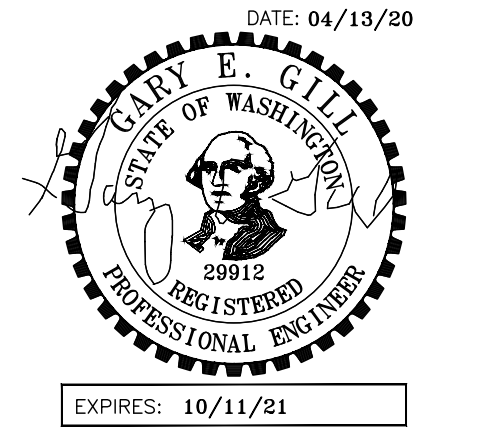

PROJECT:
AGNIESZKA & STEVE LOUDEN
3315 97TH AVE SE
MERCER ISLAND, WA

CLIENT:
LOUDEN RESIDENCE
3315 97TH AVE SE
MERCER ISLAND, WA

ISSUE:
PERMIT SET 04/13/2020

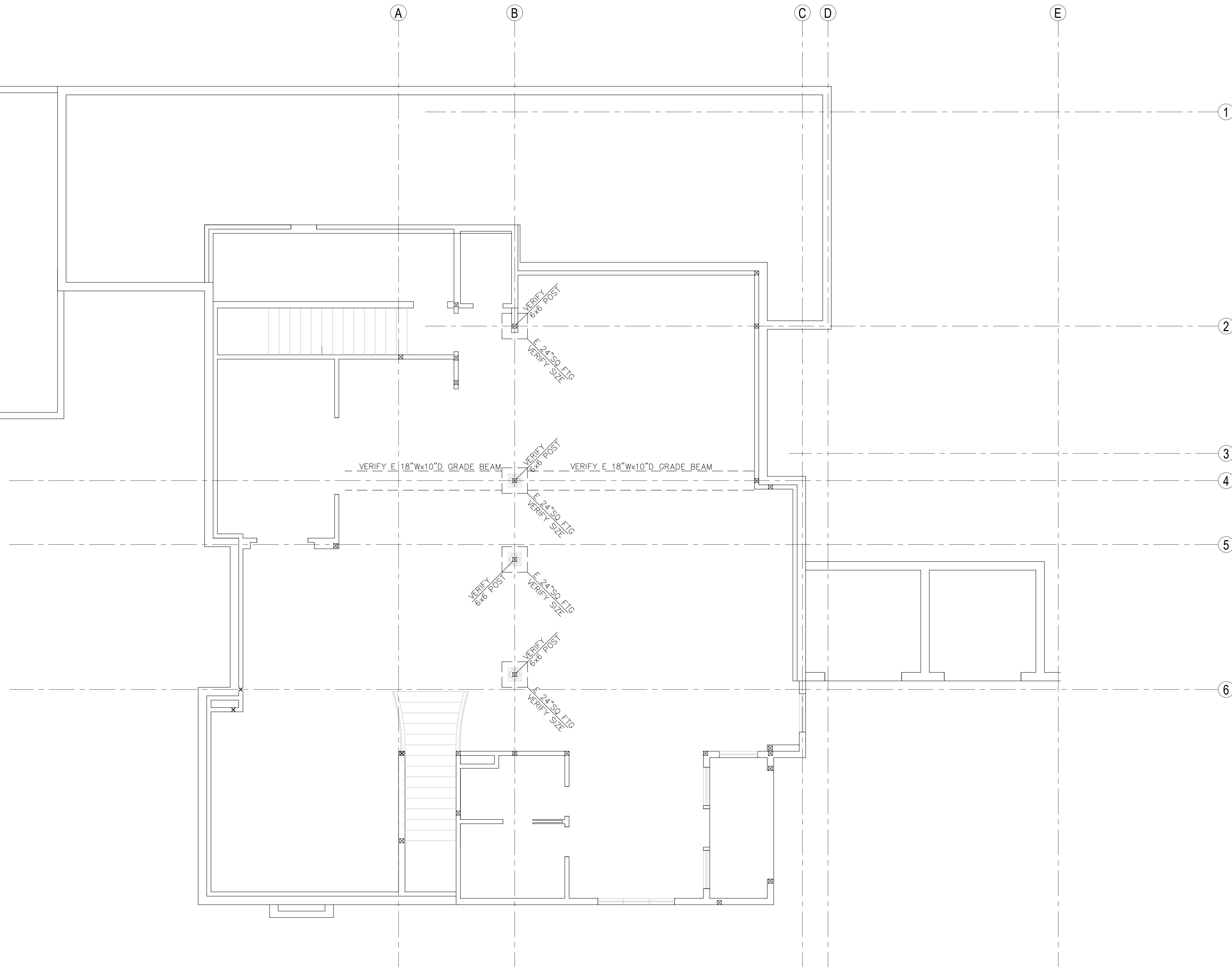

1 BASEMENT/FOUNDATION PLAN
1/4"=1'-0"

DATE:
13 APRIL 2020

SHEET TITLE:
BASEMENT FOUND

PLAN
SHEET:

S2.1

GARY GILL, SE
1125 NE 152nd STREET
SHORELINE, WA 98155
PH: 206-992-2728
GILL26608@YAHOO.COM

COPYRIGHT 2016 McLELLAN ARCHITECTS

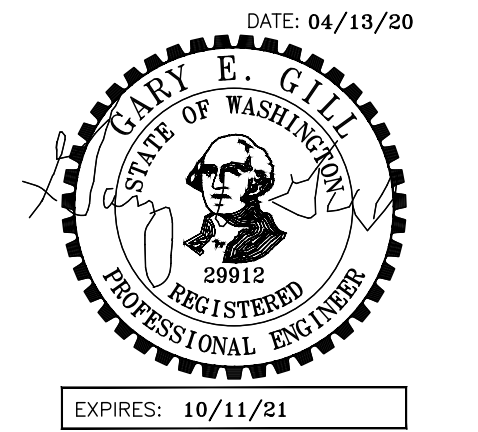

PROJECT:
AGNIESZKA & STEVE LOUDEN
3315 97TH AVE SE
MERCER ISLAND, WA

CLIENT:
LOUDEN RESIDENCE
3315 97TH AVE SE
MERCER ISLAND, WA

ISSUE:
PERMIT SET 04/13/2020

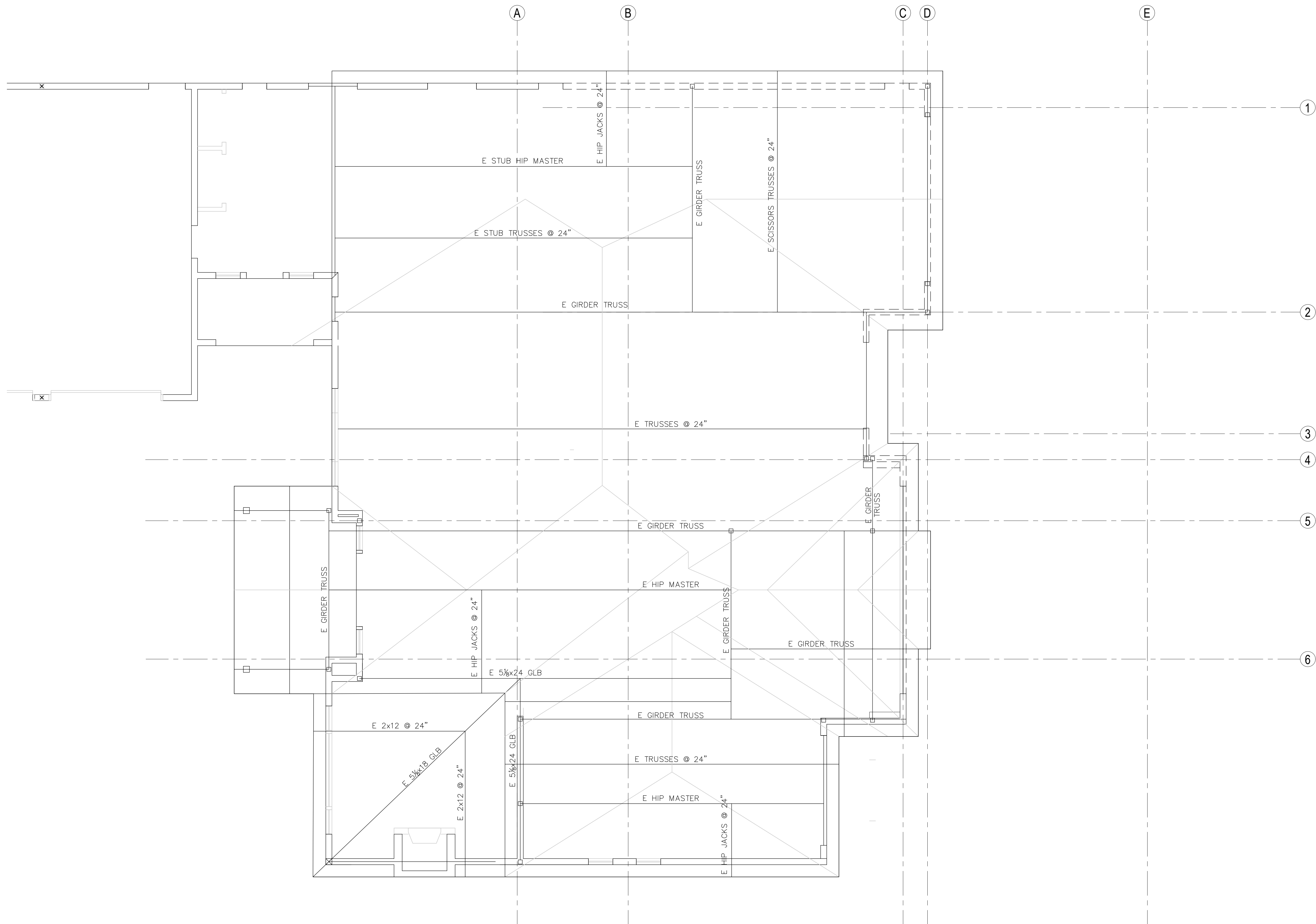

1 EXIST ROOF FRAMING PLAN
SCALE: 1/4" = 1'-0"

DATE:
13 APRIL 2020

SHEET TITLE:
EXISTING ROOF
FRAMING PLAN
SHEET:

S2.4

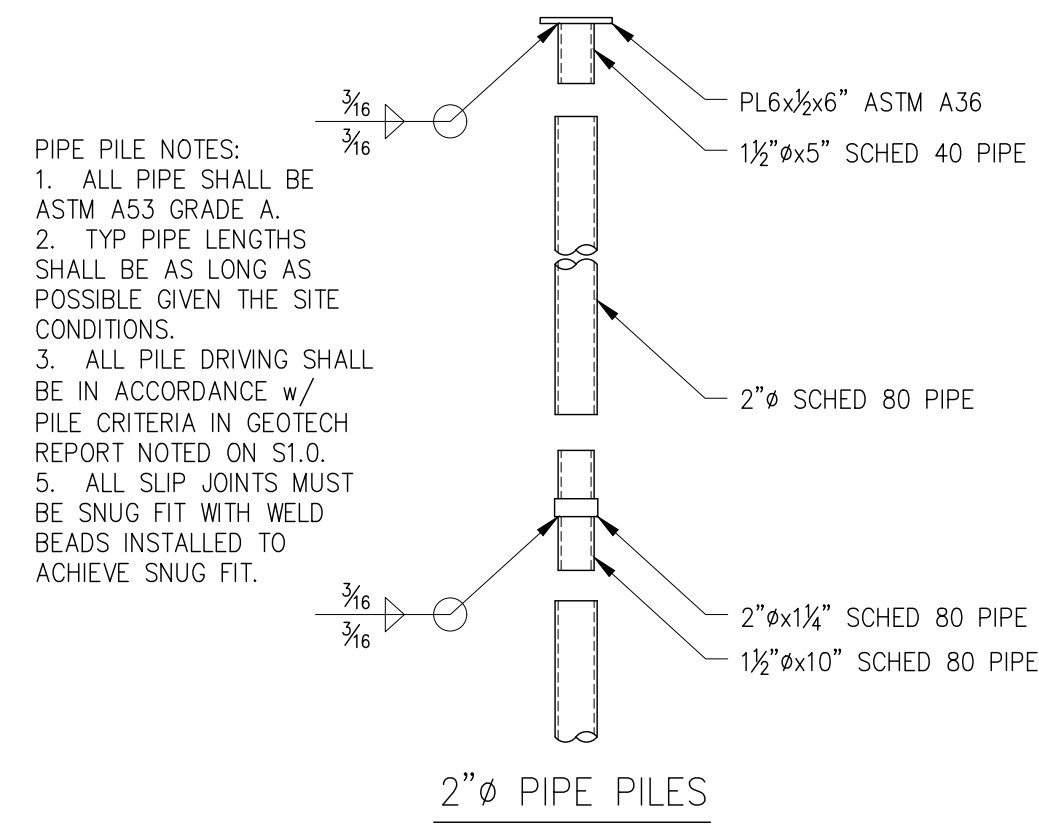

5 TYP PIPE PILE DETAILS
 S3.1 SCALE: 3/4" = 1'-0"

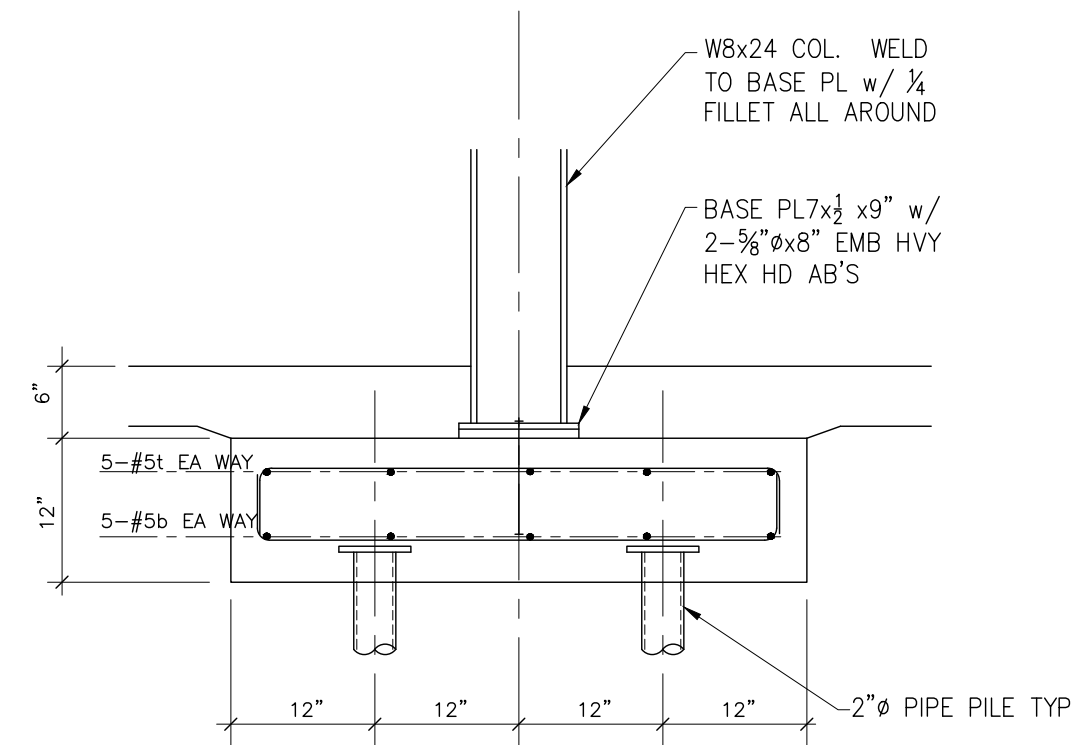

3 SECTION
 S3.1 SCALE: 3/4" = 1'-0"

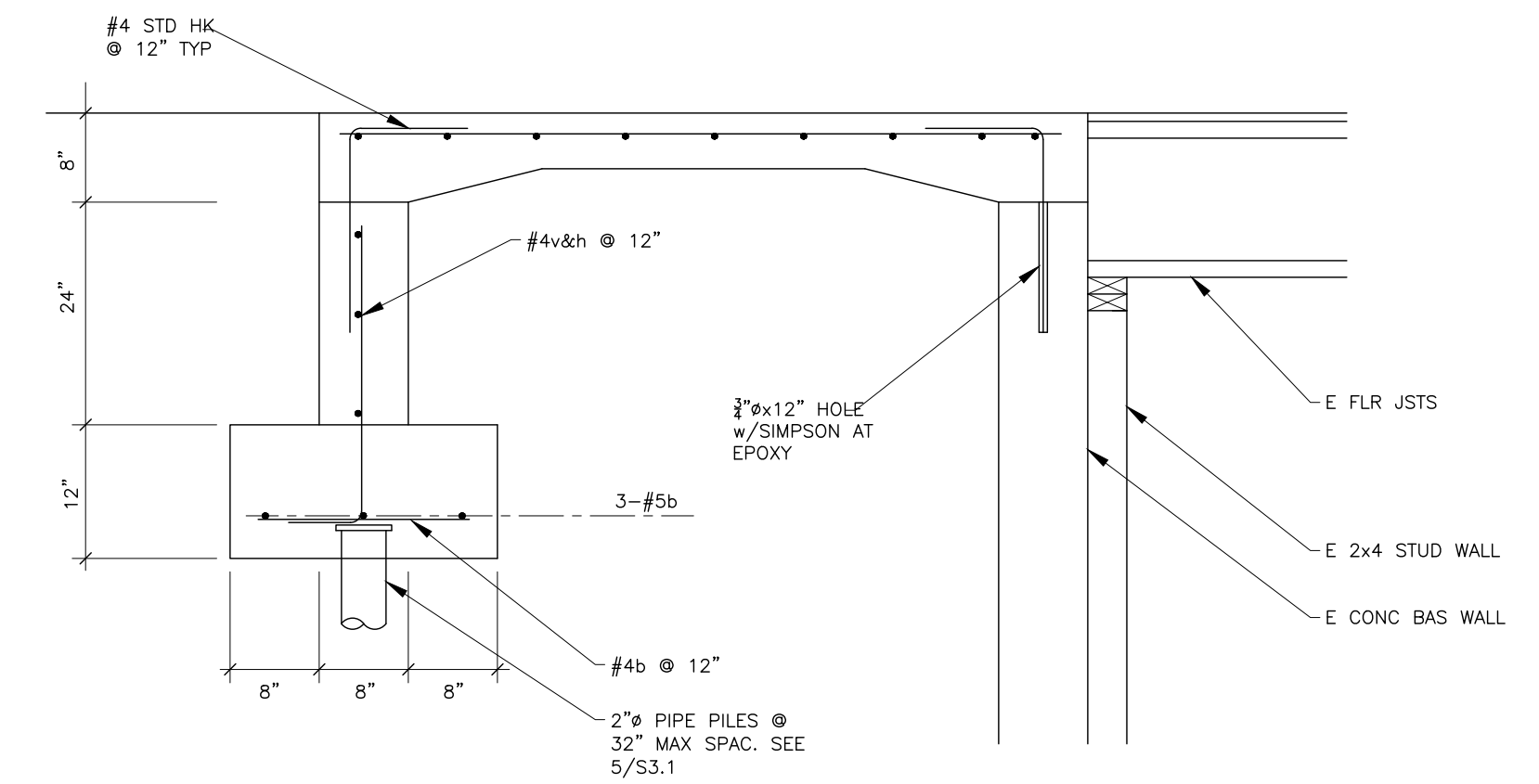

2 SECTION
 S3.1 SCALE: 3/4" = 1'-0"

GARY GILL, SE
 1125 NE 152nd STREET
 SHORELINE, WA 98155
 PH: 206-992-2728
 GILL26608@YAHOO.COM

COPYRIGHT 2016 MCLELLAN ARCHITECTS



PROJECT:
 AGNIESZKA & STEVE LOUDEN
 3315 97TH AVE SE
 MERCER ISLAND, WA

CLIENT:
 LOUDEN RESIDENCE
 3315 97TH AVE SE
 MERCER ISLAND, WA

ISSUE:
 PERMIT SET 04/13/2020

DATE:
 13 APRIL 2020

SHEET TITLE:
 FOUNDATION DETAILS

SHEET:
 S3.1

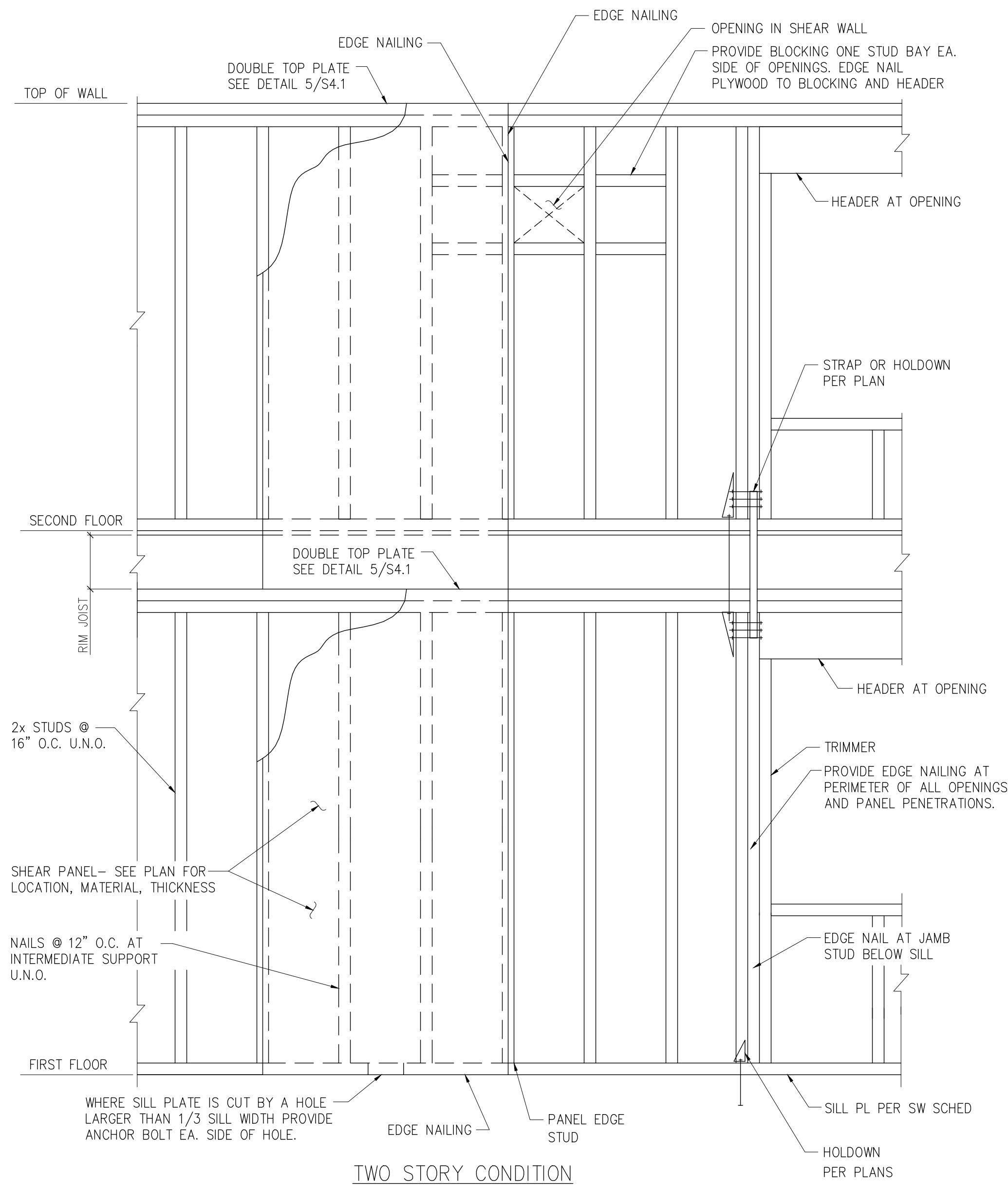

1 SHEAR WALL ELEVATION
S4.1 SCALE: 3/4" = 1'-0"

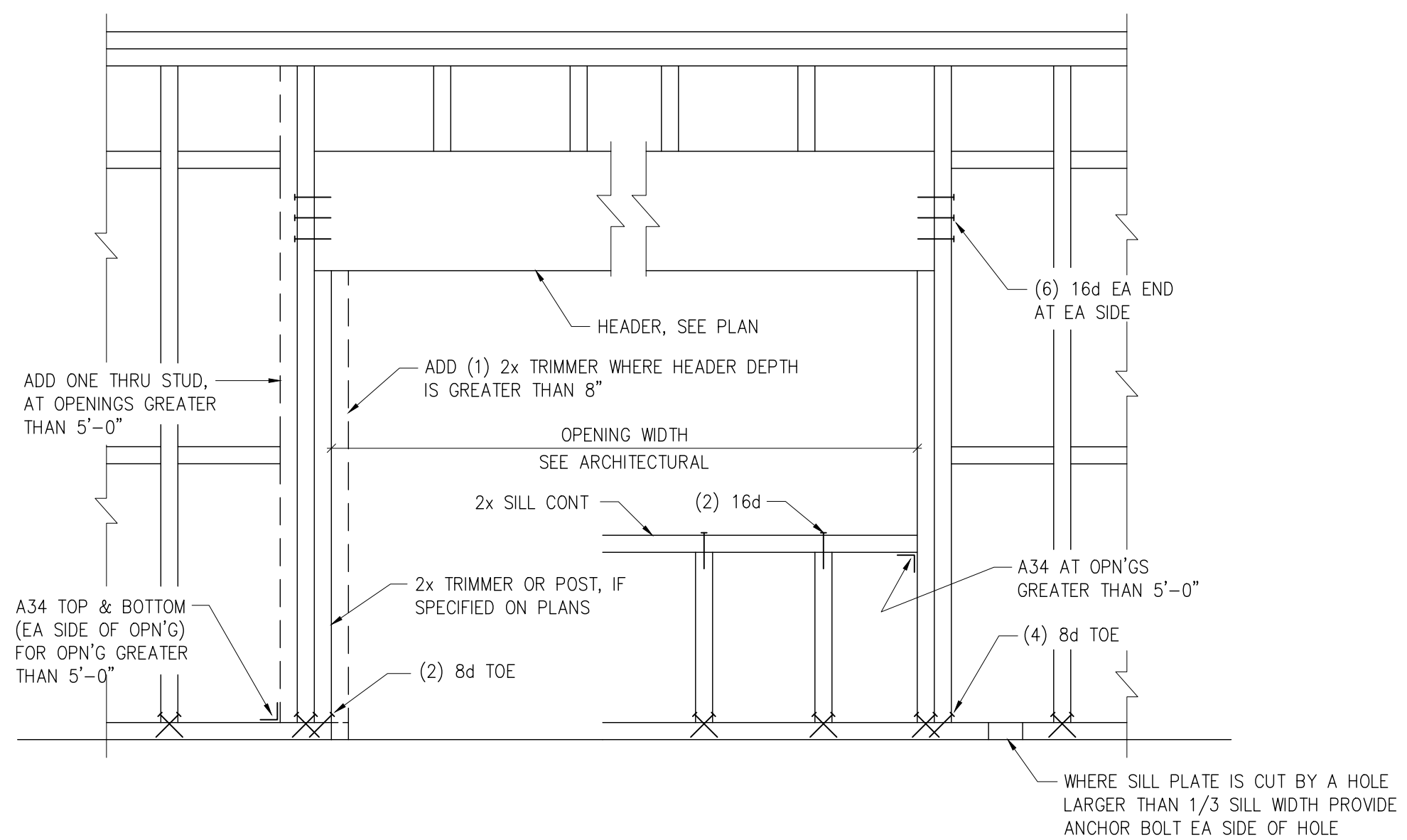

2 HEADER CONNECTION DETAIL
S4.1 SCALE: 3/4" = 1'-0"

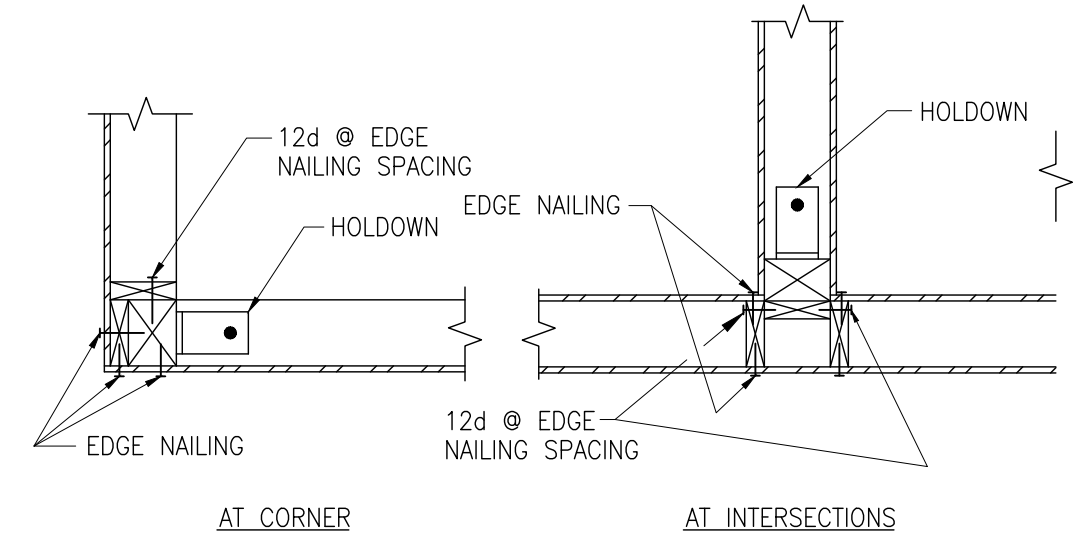

3 HOLDOWN PLAN VIEWS
S4.1 SCALE: 3/4" = 1'-0"

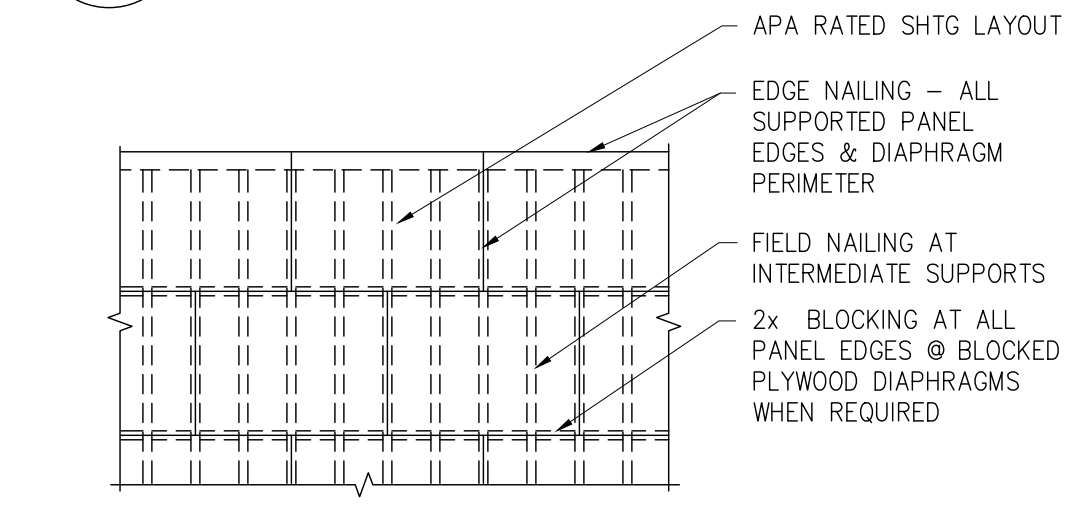

- NOTES:
1. MIN EDGE DISTANCE FOR NAILS SHALL BE 3/8".
 2. MIN SHEATHING SHEET SIZE SHALL BE 2'-0"x4'-0".
 3. NAILS SHALL NOT BE OVERDRIVEN.
 4. NAILS SHALL BE COMMON WIRE TYPE OR APPROVED EQUAL.
 5. SEE PLANS FOR AREAS OF BLOCKED DIAPHRAGMS

4 SHEATHED DIAPHRAGM CONSTRUCTION
S4.1 SCALE: 3/4" = 1'-0"

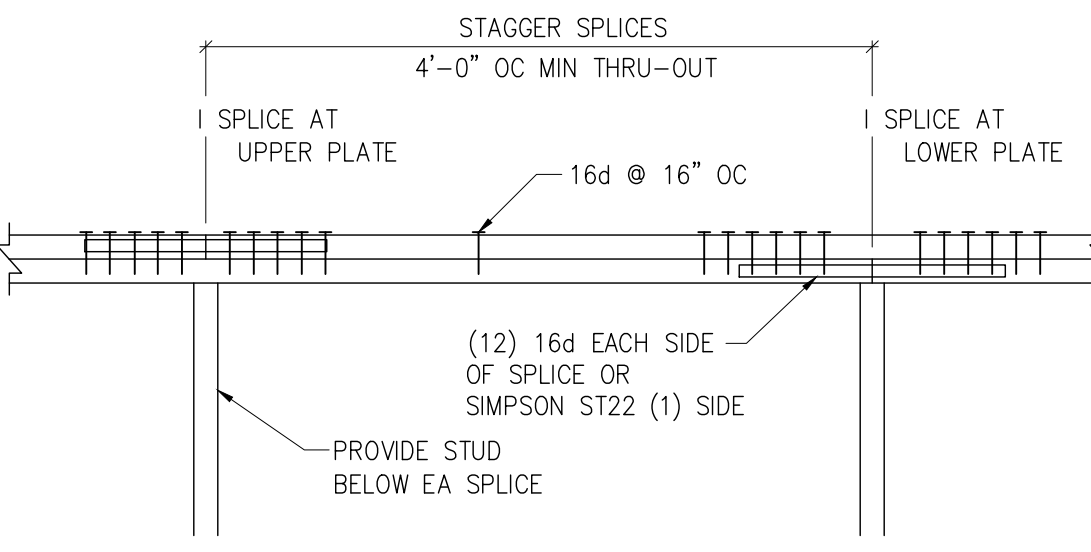

ELEVATION

5 DBL TOP PLATE SPLICE
S4.1 SCALE: 3/4" = 1'-0"

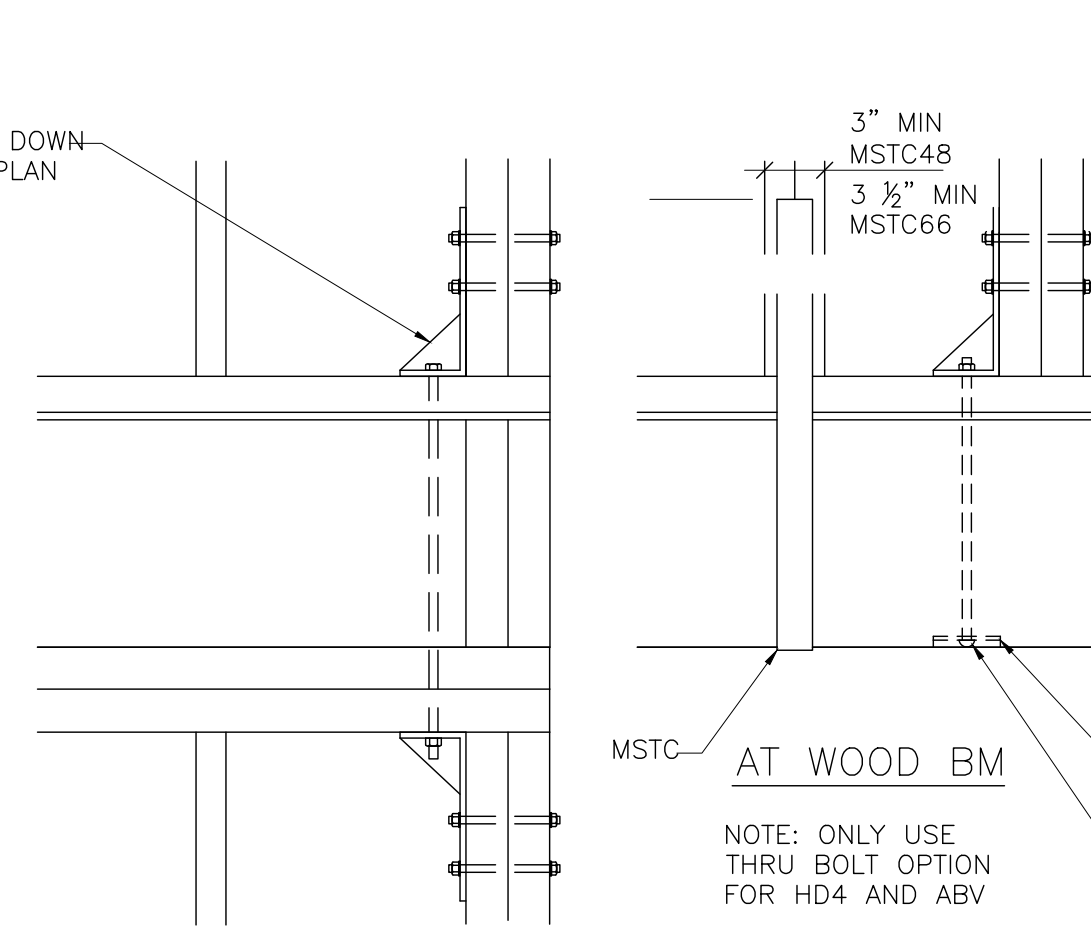

6 HOLDOWN DETAILS
S4.1 SCALE: 3/4" = 1'-0"

HOLD DOWN SCHEDULE					
MARK	HOLDOWN	ANCHOR BOLTS	STUD FASTENERS	MIN POST REQUIRED	ALLOWABLE TENSION (lbs)
					DOUG-FIR
HD1	MST1	18--.148x1 1/2" EA END	18--.148x 1 1/2" EA END	(2) 2x	3808
HD2	HDU2-SDS2.5 OR MSTC48B3 @ WD BM BEL	5/8" MB FLR TO FLR SSB16L @ CONC WALL OR FTG	6-SDS 1/4"x2 1/2" @ HDU2 38-10d @ MSTC	(2) 2x	3075
HD3	HDU4-SDS2.5 OR MSTC66B3 @ WD BM BEL	5/8" MB FLR TO FLR SB5/8x24 @ NEW CONC WALL OR FTG 5/8"x10" EMD w/ 3/4"x12" HOLE w/SIMPSON AT EPOXY @ EXIST CONC	10-SDS 1/4"x2 1/2" @ HDU4 38-10d @ MSTC	(2) 2x	4565
HD4	HDU5-SDS2.5	5/8" MB FLR TO FLR SB5/8x24 @ CONC WALL OR FTG	20-SDS 1/4"x2 1/2"	(2)2x6	5645
HD5	HDU8-SDS2.5	7/8" MB FLR TO FLR SB7/8x24 @ CONC WALL OR FTG	20-SDS 1/4"x2 1/2"	4x6	6970
HD6	HDU14-SDS2.5	1" MB FLR TO FLR SB1x30 @ CONC WALL OR FTG	36-SDS 1/4"x2 1/2"	6x6	14445

- HOLD DOWN NOTES:
1. HOLD DOWNS ARE REQUIRED AS SHOWN ON THE FRAMING PLANS.
 2. AT CORNERS COMMON TO TWO SHEAR WALLS USE THE LARGER OF THE HOLD DOWNS ONLY.
 3. ALL HOLD DOWN COLUMNS SHALL BE DF.
 4. HOLD DOWN ANCHOR BOLTS THAT OCCUR ABOVE A WF BEAM SHALL BE WELDED DIRECTLY TO THE WF BEAM BELOW SO THAT THE FULL CAPACITY OF THE ANCHOR BOLT IS DEVELOPED.
 5. ALL HOLD DOWNS SHALL BE CONNECTED TO POSTS BELOW AND A BEAM BELOW. SEE 6/- FOR DETAILS.
 6. ALL CALLOUTS REFER TO SIMPSON STRONGTIE PRODUCTS. OTHER MANUFACTURED HOLD DOWNS MAY BE SUBSTITUTED PROVIDED THAT TESTING DATA IS PROVIDED TO VERIFY THAT THE VALUES LISTED WILL BE MET OR EXCEEDED.

SHEAR WALL SCHEDULE								
MARK	APA RATED SHEATHING	NAILING AT PANEL EDGES	PANEL EDGE STUD AND BLKG	RIM JOIST OR BLOCK CONNECTION TO TOP PLATE	HEM-FIR (NORTH), BOTTOM PLATE ATTACHMENT TO WOOD BELOW	HEM-FIR (NORTH), SILL PLATE ATTACHMENT		CAPACITY (plf)
						ANCHOR BOLT	SILL	
SW1	15/32" PLYWOOD SHEATHING, ONE SIDE	10d @ 6" OC	2X	A35 @ 16" OC	(2) 16d @ 16" OC OR 5/8" LAG SCREWS @ 32" OC	3/4" @ 48" OC OR @ MTL DK 0.177" PAF @ 6"	2X MIN	310
SW2	15/32" PLYWOOD SHEATHING, ONE SIDE	10d @ 4" OC	3X MIN	A34 AND LTP4 16" OC	(2) 16d @ 8" OC OR 5/8" LAG SCREWS @ 16" OC	3/4" @ 24" OC	3X MIN	460
SW3	15/32" PLYWOOD SHEATHING, ONE SIDE	10d @ 3" OC	3X MIN	A35 AND LTP4 16" OC	5/8" LAG SCREWS @ 12" OC	3/4" @ 18" OC	3X MIN	600
SW4	15/32" PLYWOOD SHEATHING, ONE SIDE	10d @ 2" OC	3X MIN	A35 AND LTP4 16" OC	5/8" LAG SCREWS @ 8" OC	3/4" @ 12" OC	3X MIN	770
SW5	15/32" PLYWOOD SHEATHING, TWO SIDES	10d @ 3" OC	3X MIN	A35 AND LTP4 8" OC	5/8" LAG SCREWS @ 4" OC	3/4" @ 8" OC	3X MIN	1200
SW6	SIMP WOOD SHEAR WALL WSW24x7	NA	NA	PER SIMPSON	PER SIMPSON	PER SIMPSON	PER SIMP	2770

- SHEAR WALL NOTES:
1. INSTALL PANELS EITHER HORIZONTALLY OR VERTICALLY.
 2. WHERE SHEATHING IS APPLIED ON BOTH FACES OF WALL, PANEL JOINTS SHALL BE STAGGERED SO THAT JOINTS ON OPPOSITE SIDES ARE NOT LOCATED ON THE SAME STUDS.
 3. BLOCKING IS REQUIRED AT ALL PANEL EDGES.
 4. PROVIDE SHEARWALL SHEATHING AND NAILING FOR THE ENTIRE LENGTH OF WALLS INDICATED ON PLAN.
 5. INTERMEDIATE FRAMING TO BE WITH 2X MINIMUM MEMBERS. FIELD NAILING @ 12" OC.
 6. PROVIDE HOT-DIPPED GALVANIZED (ELECTRO-PLATING IS NOT ACCEPTABLE) NAILS AND CONNECTOR PLATES FOR ALL CONNECTORS IN CONTACT WITH PRESSURE TREATED FRAMING MEMBERS.
 7. WHERE BOTTOM PLATE ATTACHMENT SPECIFIES (2) ROWS OF NAILS, PROVIDE DOUBLE JOIST, RIM OR EQUAL. ATTACH PER DETAILS.
 8. ALL SHEAR WALL FRAMING TO BE DF. NO OTHER SPECIES ALLOWED.

SHEAR WALL & HOLD DOWN SCHEDULES

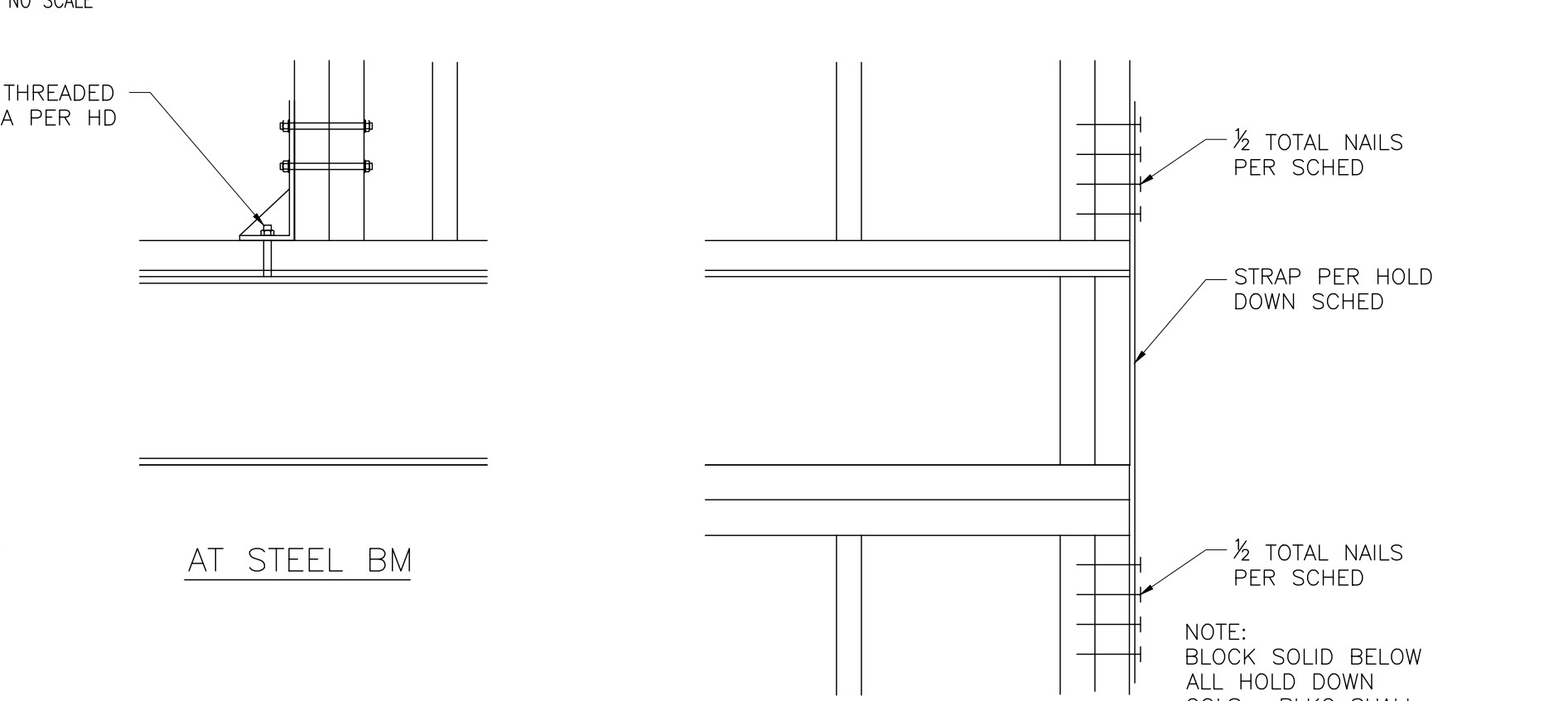

GARY GILL, SE
1125 NE 152nd STREET
SHORELINE, WA 98155
PH: 206-992-2728
GILL26608@YAHOO.COM

COPYRIGHT 2016 MCLELLAN ARCHITECTS



PROJECT:
AGNIESZKA & STEVE LOUDEN
3315 97TH AVE SE
MERCER ISLAND, WA

CLIENT:
LOUDEN RESIDENCE
3315 97TH AVE SE
MERCER ISLAND, WA

ISSUE:
PERMIT SET 04/13/2020

DATE:
13 APRIL 2020

SHEET TITLE:
TYP FRAMING

DETAILS
SHEET:

S4.1

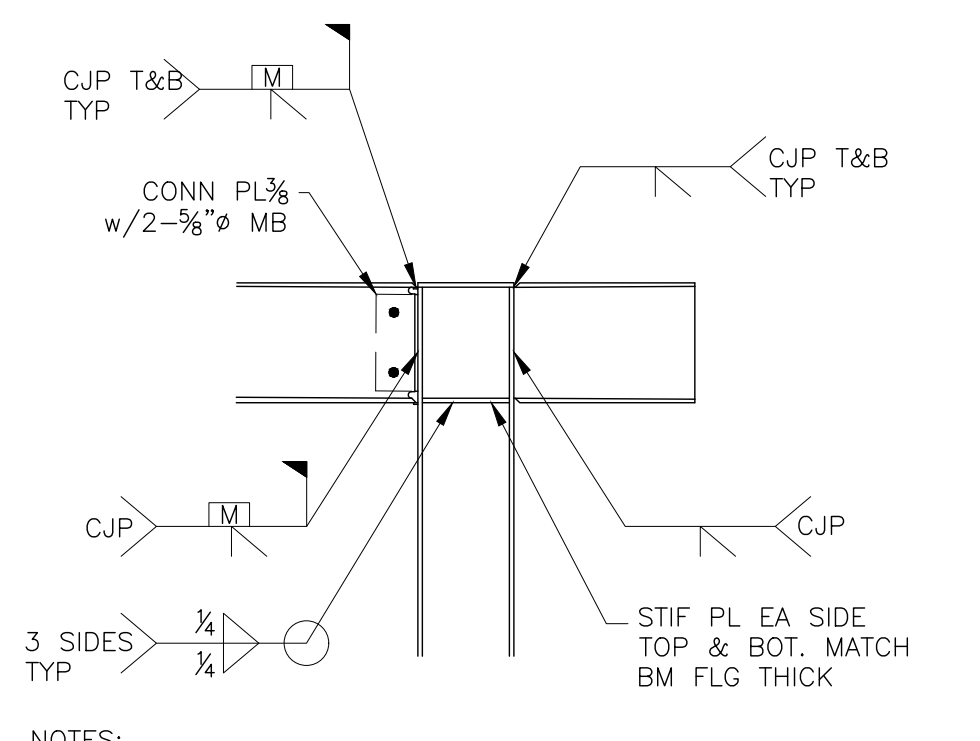

NOTES:
 1. CJP WELD FILLER METALS MUST MEET AWS D1.8 CLAUSE 6.3.
 2. AFTER FIELD WELDS ARE IN PLACE, REMOVE CONNECTION PLATE AND BACKER BARS AND WELD SOLID BOLT HOLES. GRIND ALL SURFACES SMOOTH.

5 SECTION
 S4.2 SCALE: 3/4" = 1'-0"

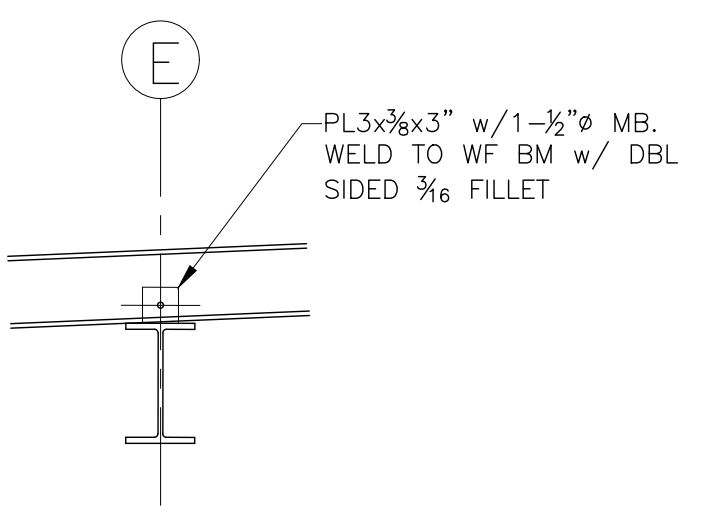

4 SECTION
 S4.2 SCALE: 3/4" = 1'-0"

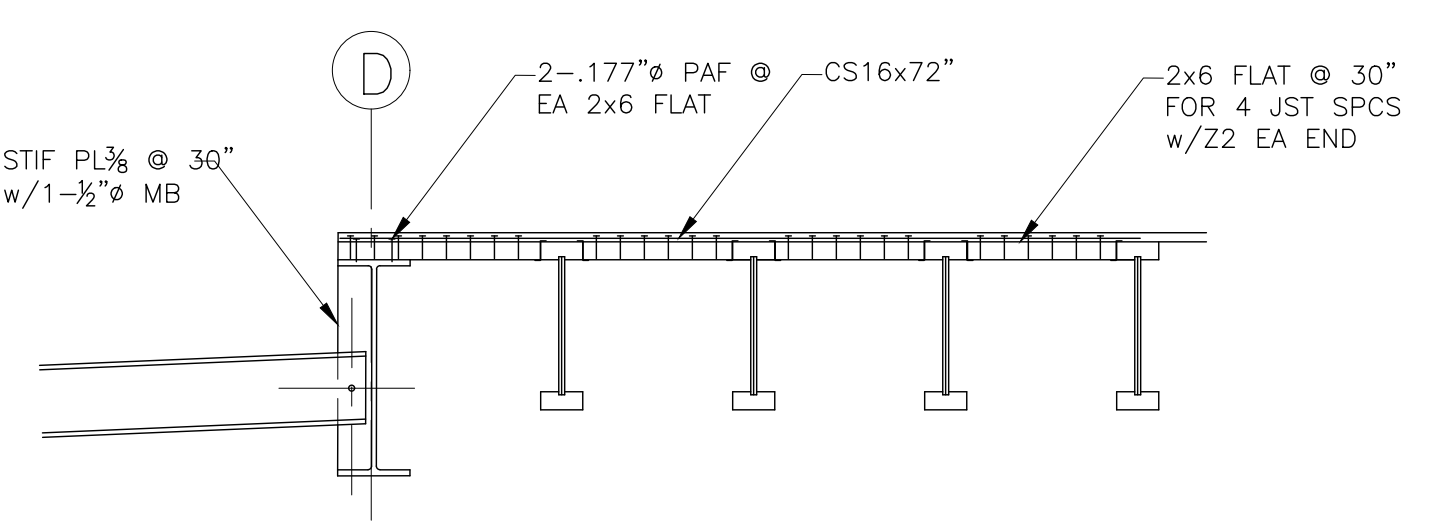

3 SECTION
 S4.2 SCALE: 3/4" = 1'-0"

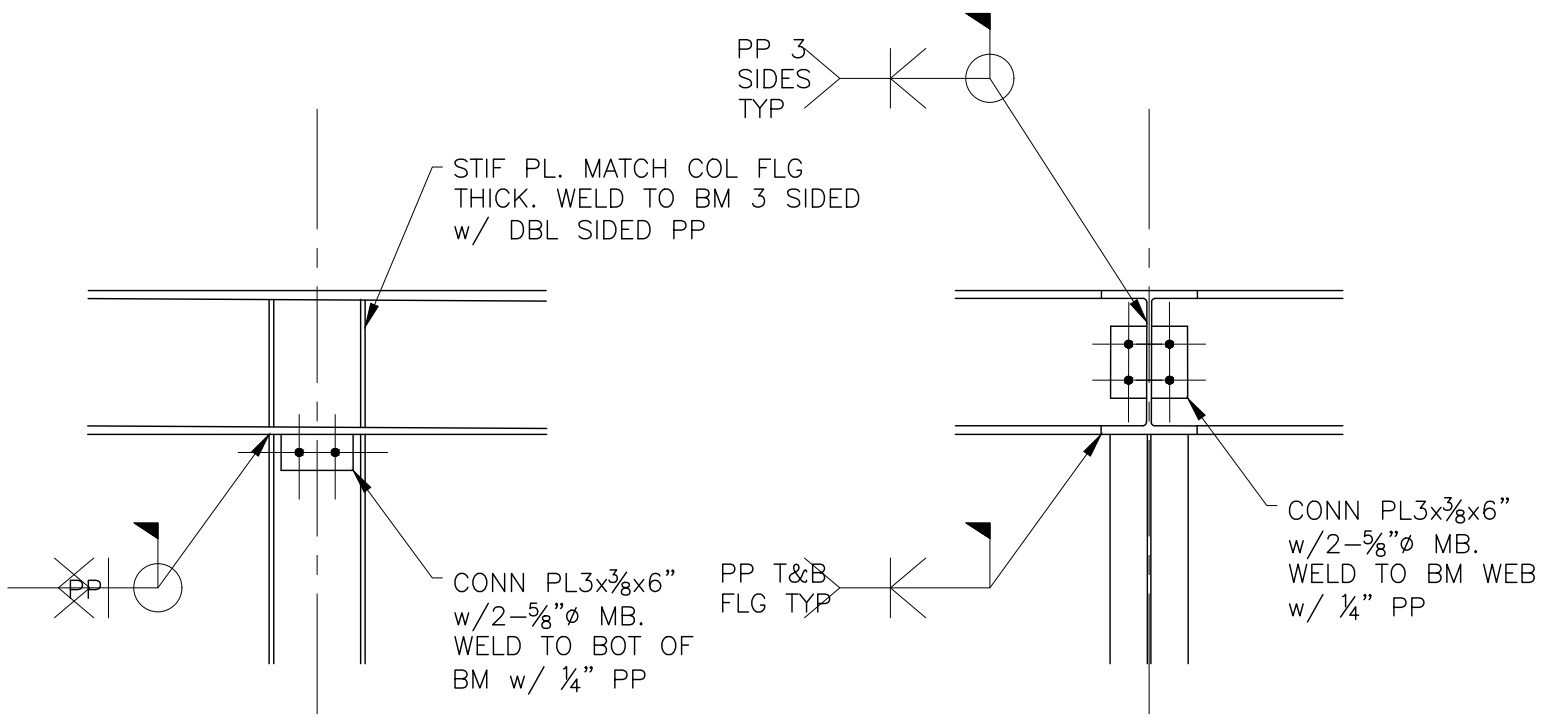

NOTES:
 1. AFTER FIELD WELDS ARE IN PLACE, REMOVE CONNECTION PLATE AND WELD SOLID BOLT HOLES. GRIND ALL SURFACES SMOOTH.

10 SECTION
 S4.2 SCALE: 3/4" = 1'-0"

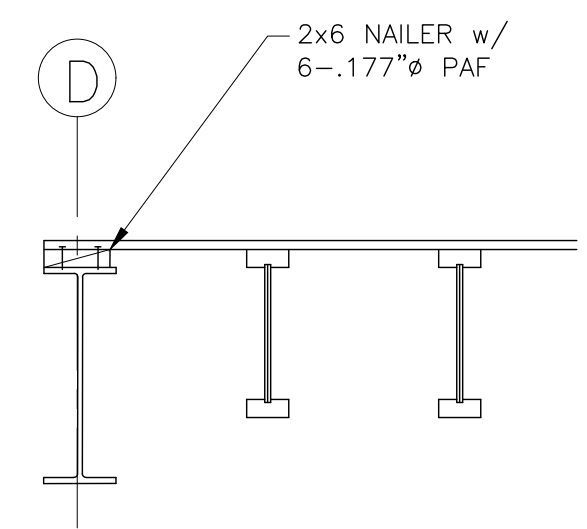

8 SECTION
 S4.2 SCALE: 3/4" = 1'-0"

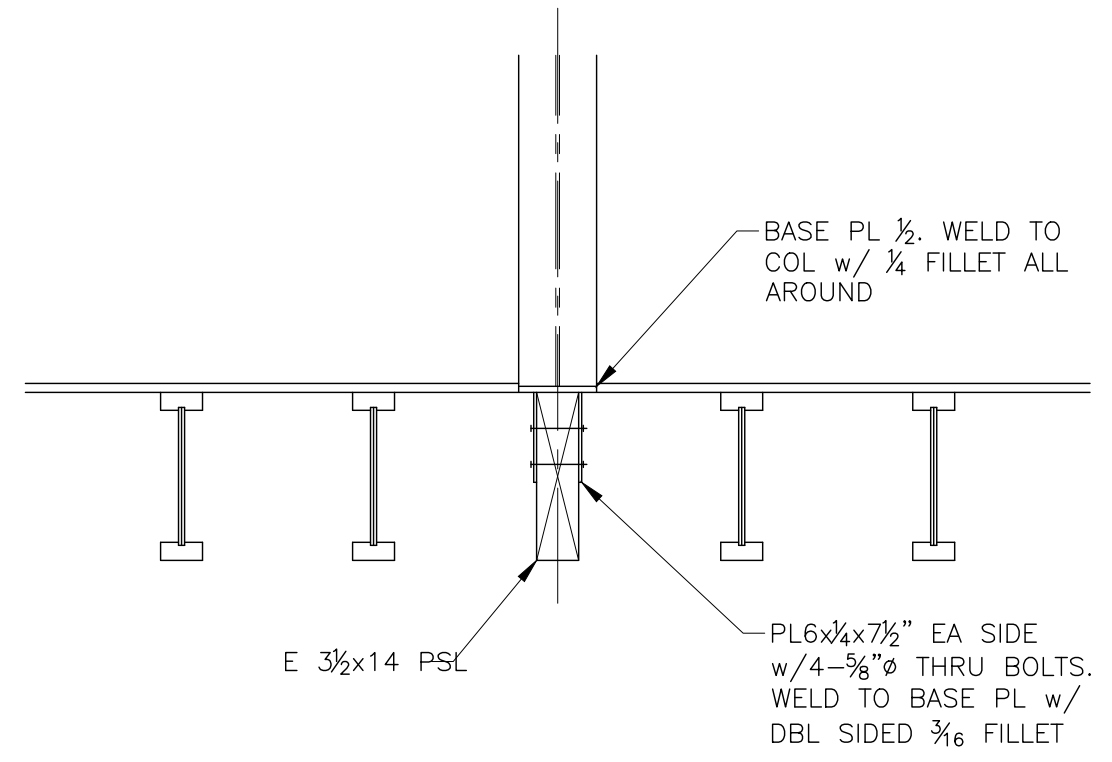

7 SECTION
 S4.2 SCALE: 3/4" = 1'-0"

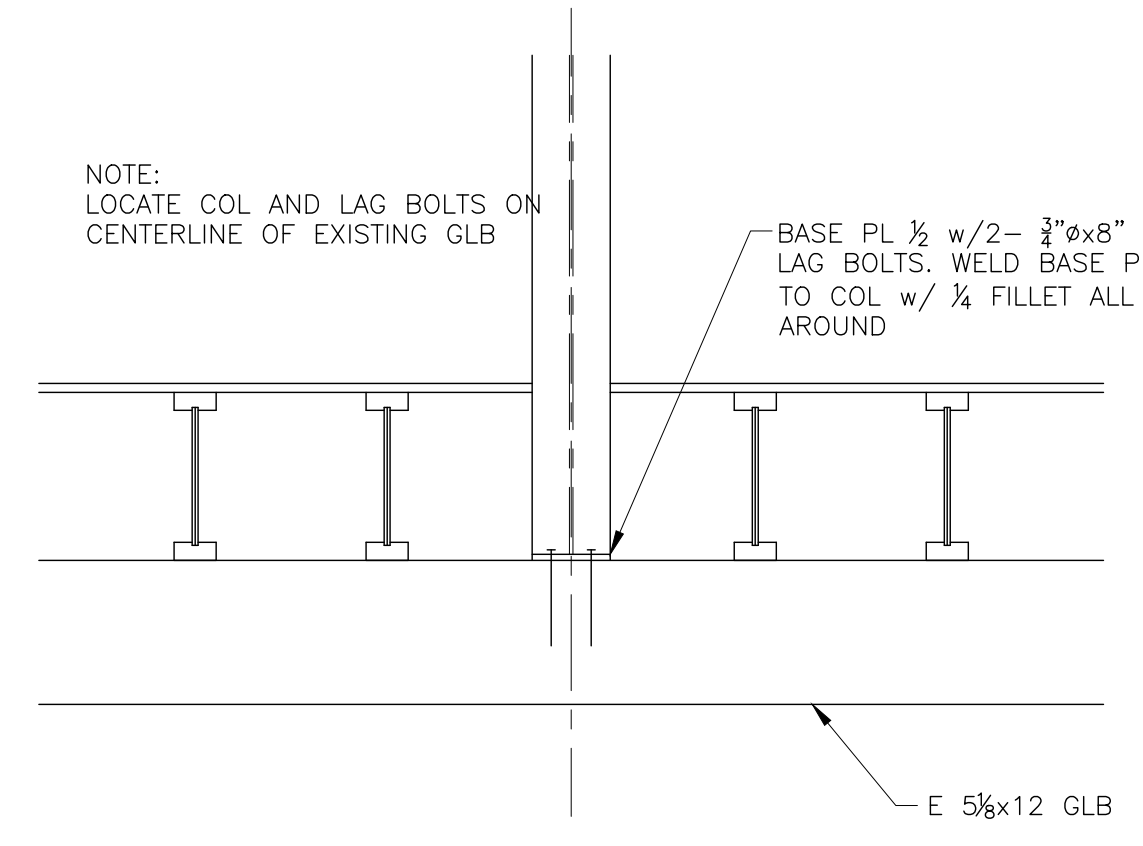

6 SECTION
 S4.2 SCALE: 3/4" = 1'-0"

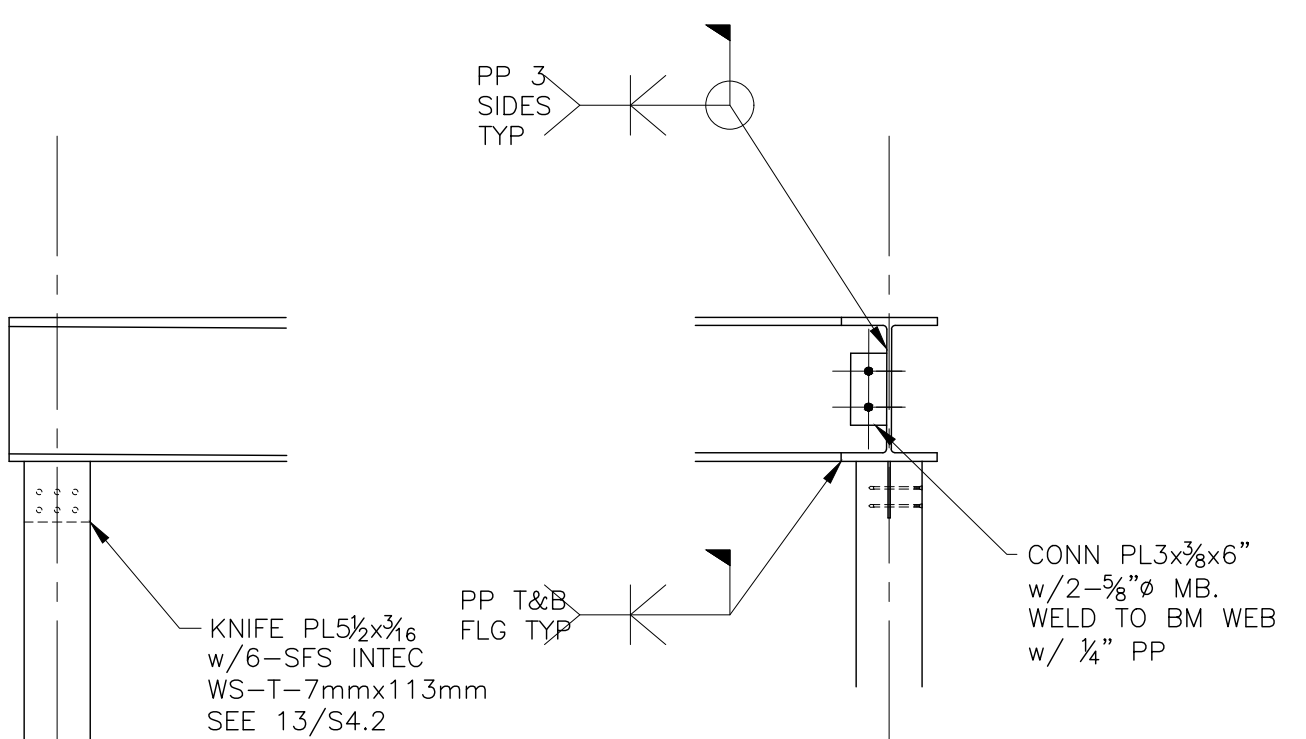

NOTES:
 1. AFTER FIELD WELDS ARE IN PLACE, REMOVE CONNECTION PLATE AND WELD SOLID BOLT HOLES. GRIND ALL SURFACES SMOOTH.

15 SECTION
 S4.2 SCALE: 3/4" = 1'-0"

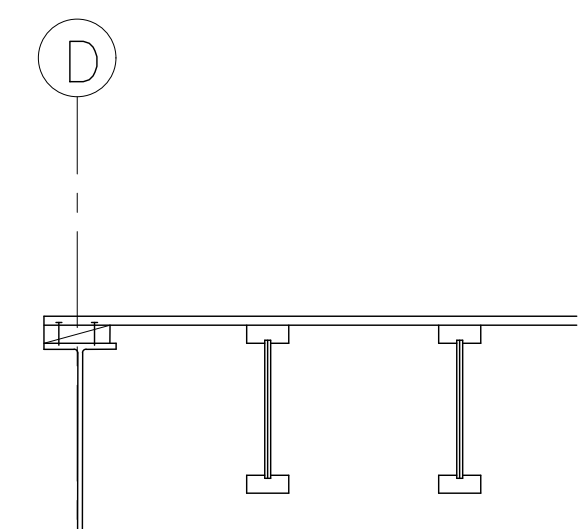

13 SECTION
 S4.2 SCALE: 3/4" = 1'-0"

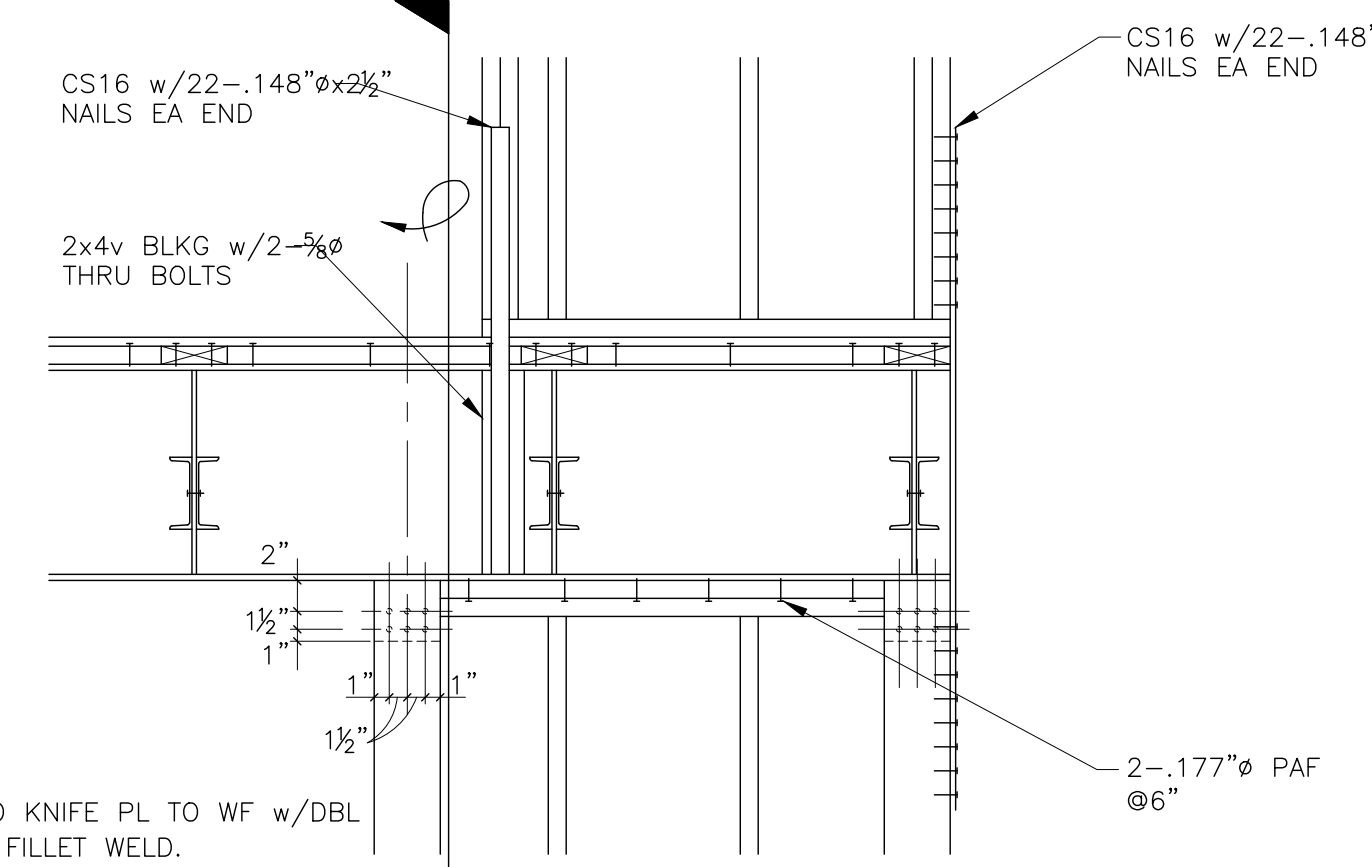

11 SECTION
 S4.2 SCALE: 3/4" = 1'-0"

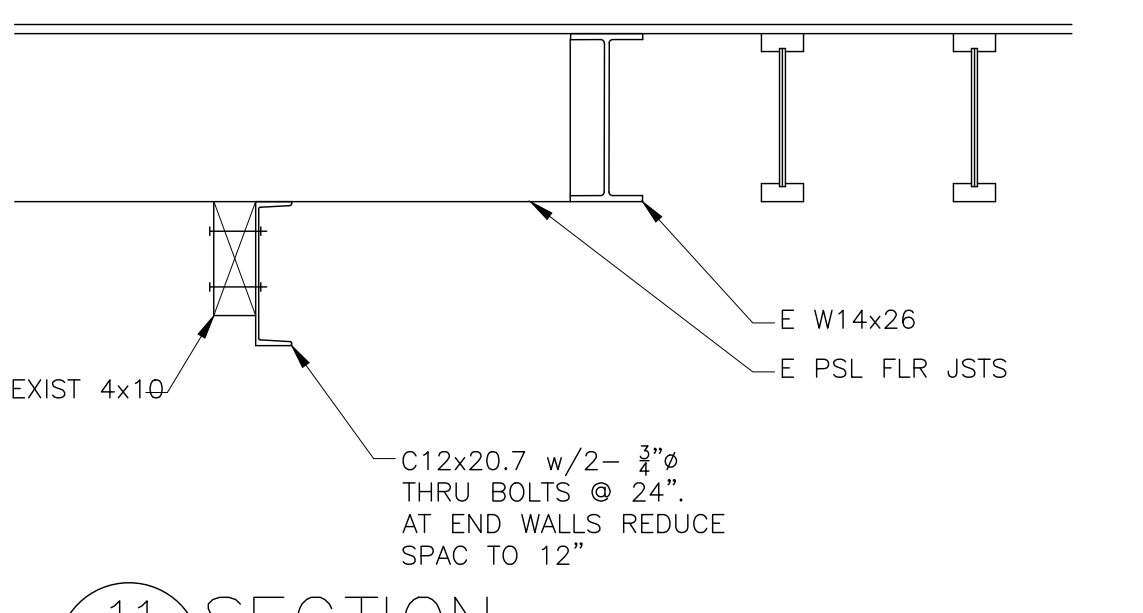

16 SECTION
 S4.2 SCALE: 3/4" = 1'-0"

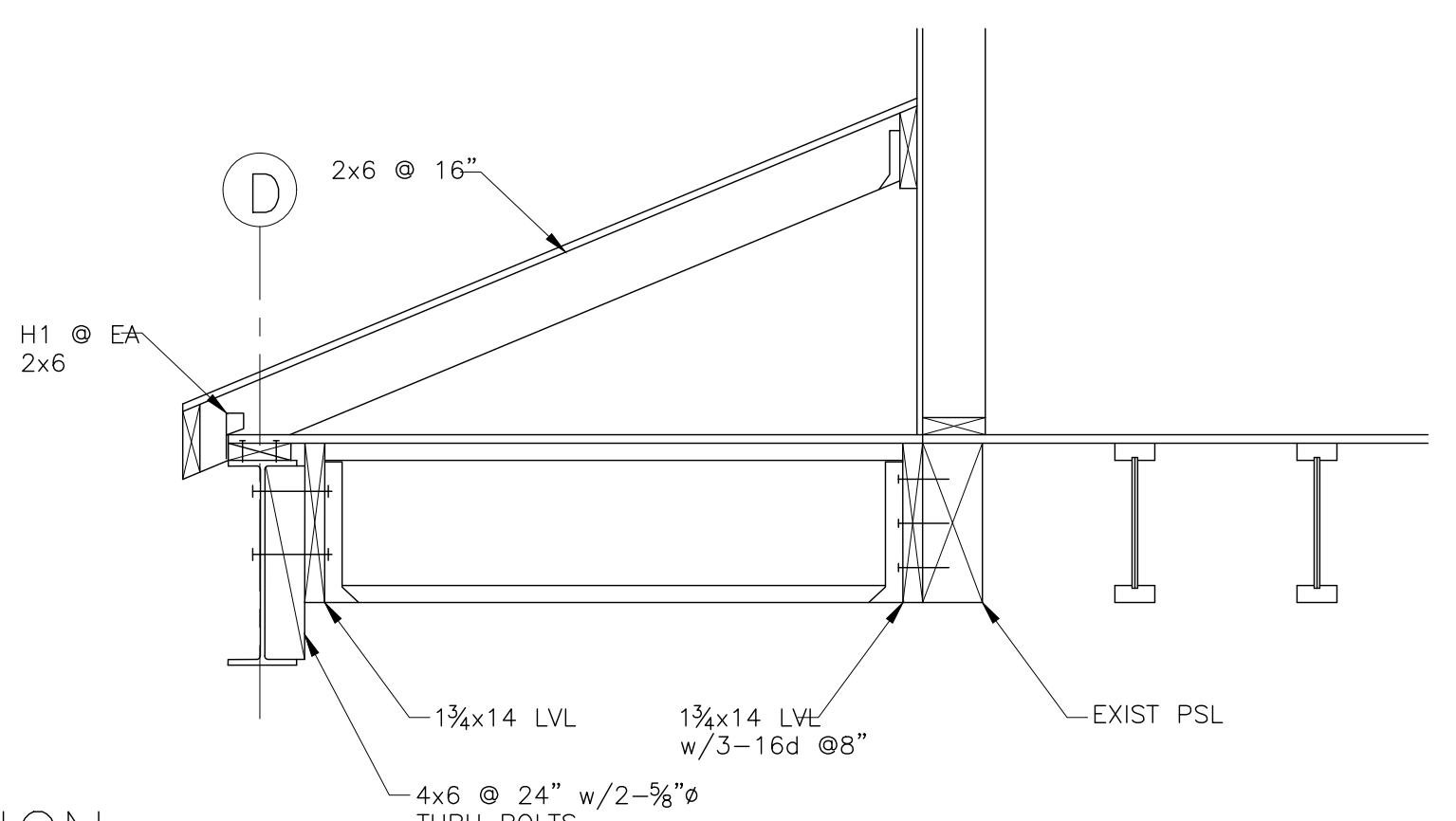

20 SECTION
 S4.2 SCALE: 3/4" = 1'-0"

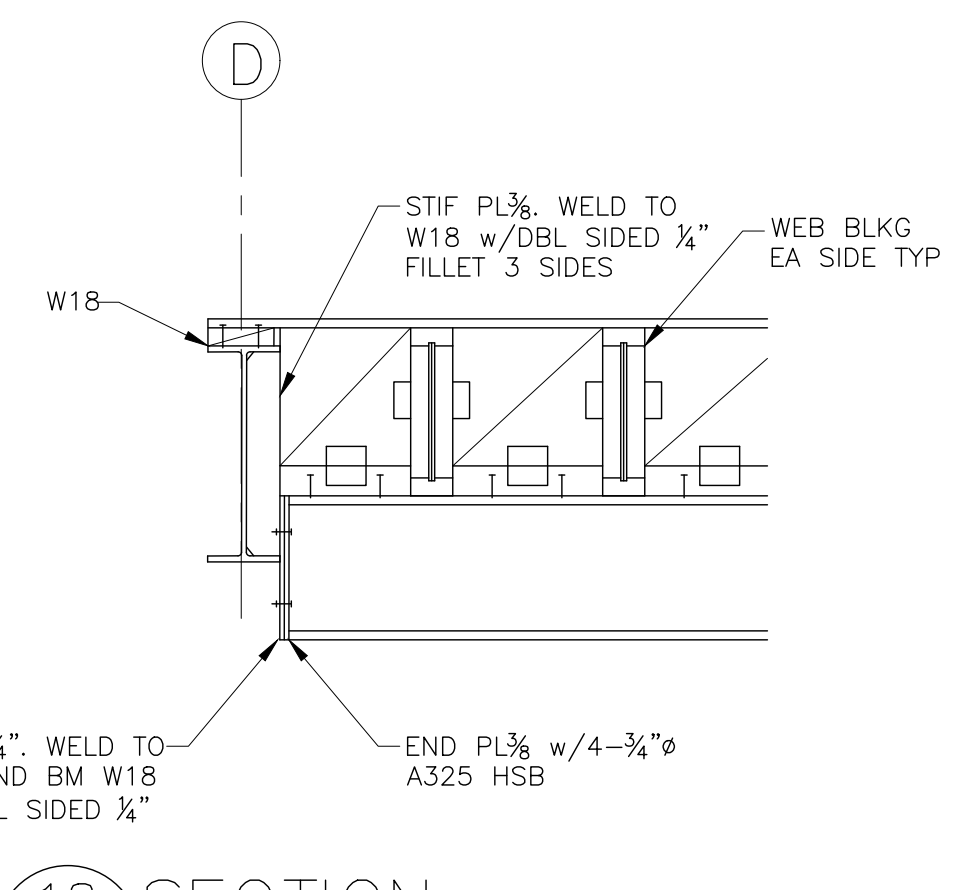

18 SECTION
 S4.2 SCALE: 3/4" = 1'-0"

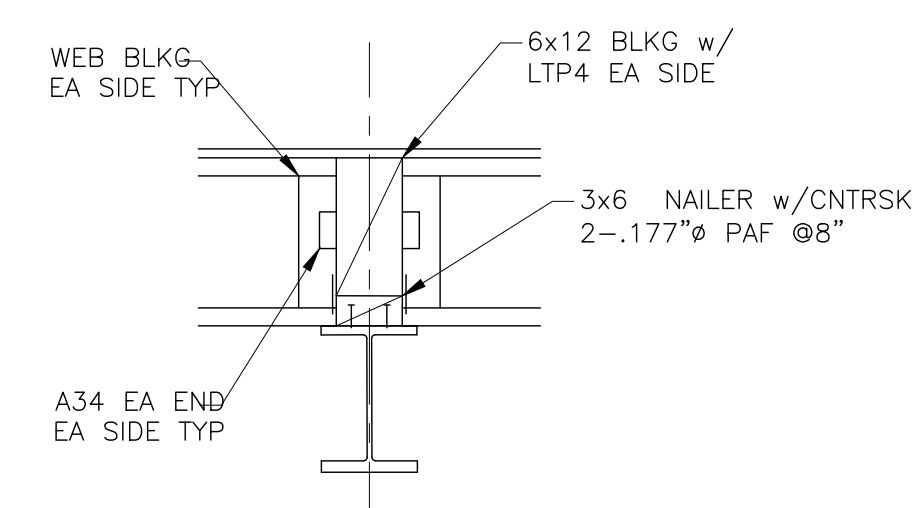

17 SECTION
 S4.2 SCALE: 3/4" = 1'-0"

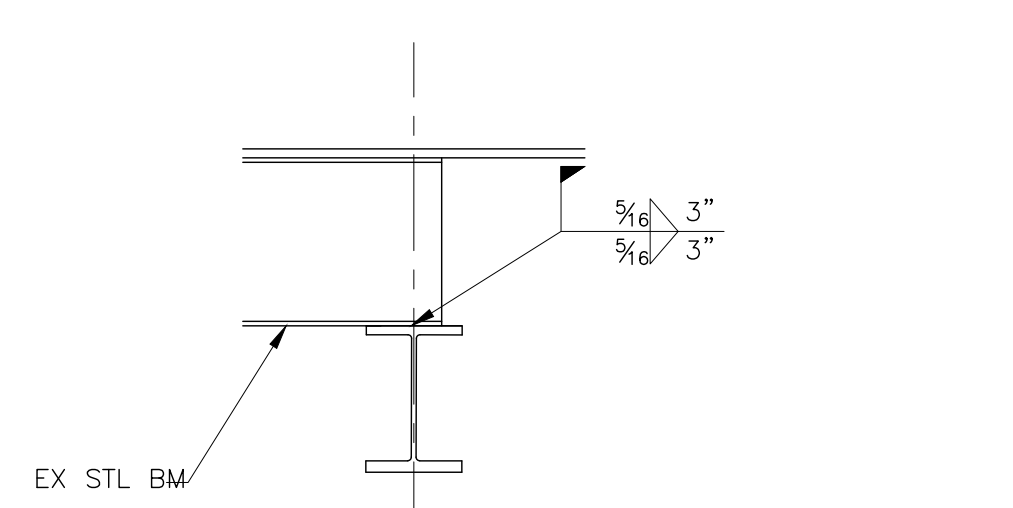

19 SECTION
 S4.2 SCALE: 3/4" = 1'-0"

GARY GILL, SE
 1125 NE 152nd STREET
 SHORELINE, WA 98155
 PH: 206-992-2728
 GILL26608@YAHOO.COM

COPYRIGHT 2016 MCLELLAN ARCHITECTS



PROJECT:
 AGNIESZKA & STEVE LOUDEN
 3315 97TH AVE SE
 MERCER ISLAND, WA

CLIENT:
 LOUDEN RESIDENCE
 3315 97TH AVE SE
 MERCER ISLAND, WA

ISSUE:
 PERMIT SET
 04/13/2020

DATE:
13 APRIL 2020

SHEET TITLE:
FRAMING DETAILS

SHEET:
S4.2